

MECHANICAL TEMPERATURE

Bimetal Operating Principle

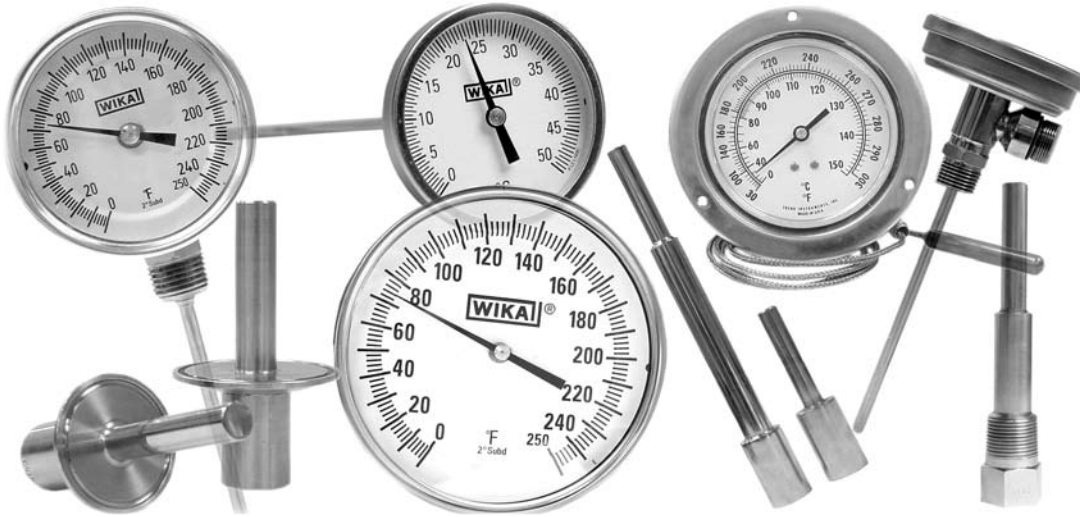

The temperature is measured with a bimetal system inside the thermometer stem. The bimetal system consists of two metal strips bonded together that have different expansion coefficients. Therefore, one strip will expand faster than the other causing the bimetal strip to curl in proportion to its temperature. The bimetal system is helically wound and heat treated for long term stability. Temperature variations cause the bimetal strip to unwind or wind tighter, which in turn rotates the pointer.

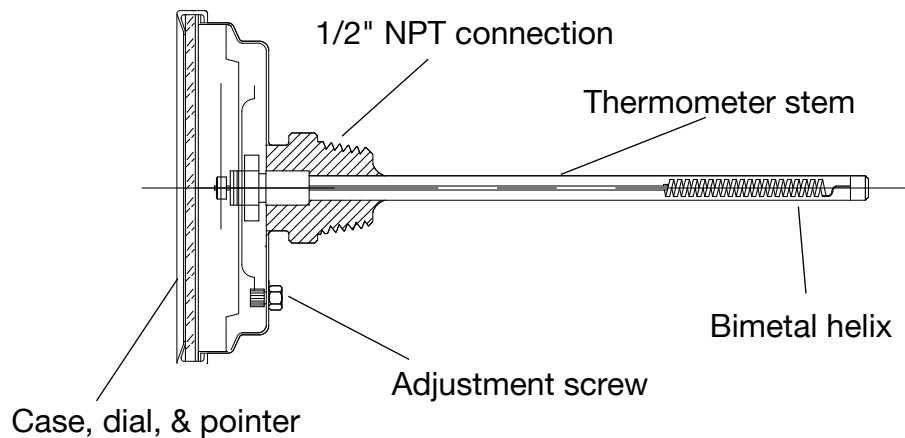

Bimetal Thermometers

General Specifications



Case: Sturdy, corrosion resistant series 304 stainless steel case and bezel. Designed and constructed to provide a hermetic seal which prevents crystal fogging and damage caused by moisture to the working components. Install thermometer so the maximum temperature case is kept below 200°F at all times.

Dial: Anti-parallax heavy gauge aluminum with white matte finish to reduce glare. Dished form with Celsius on lower inner plane and Fahrenheit on raised outer plane offers accurate indication of both scales (if equipped with dual scales).

External Reset: (comes standard on all process grade bimetal thermometers) A slotted-hex adjustment head offers screwdriver or wrench use to field calibrate the thermometer. This feature allows maximum accuracy at a selected area of temperature range. O-ring gasket prevents leakage and maintains weather tight seal. Note - use well-agitated bath and accurate test thermometer when making any adjustment.

Standards: WIKA manufactures ASME B40.3 bimetal thermometers, which meet or exceed the standard issued by the American Society of Mechanical Engineers.

Window: Optically clear, strong glass, gasketed to maintain weather tight integrity. Acrylic and Lexan windows are available as an option but not recommended for case temperature exceeding 200°F° maximum (150°F for plastic/acrylic window).

Pointer: Balanced, lightweight aluminum with matte black finish.

Stem: 304ss welded at tip and case connector to prevent leakage. ¼" diameter is standard, ⅜" is available. Stem lengths to 72" are available as well as 316ss stem and connector assemblies.

Immersion: For accurate temperature readings, immerse the stem a minimum of 2" in agitated liquid or 4" in moving air or gas.

Over Range: Temporary over or under range of 50% of scale up to 500°F or 260°C will not affect the instrument's accuracy.

Bimetal Element: An extremely responsive temperature sensing helix which has been carefully sized and tested, heat treated and aged to relieve inherent stresses and ensure continued accuracy.

Accuracy: Guaranteed to be accurate to within 1% of full scale (Grade A per ASME B40.3). Calibration is to standards traceable to the National Institute of Standards and Technology.

Hermetic Seal: Hermetically sealed per ASME B40.3. Guaranteed not to fog up.

Dampening: Inert gel to minimize pointer oscillation.

7-Year Warranty: WIKA extends a 7-YEAR WARRANTY on standard types 30, 31, 50, 51, 32, & 52. Such units are guaranteed to be free from defects in material and workmanship under normal use and service. For all other models, WIKA extends a 1-year warranty. Complete details available upon request.

Filled Thermometer Policy: Silicone filling is available on selected types for ranges between -40°F and 500°F. WIKA does not recommend use of filled instruments for continual use at operating temperatures above of 400°F (204°C) or below -100° F(-70° C). Under no circumstances will an instrument warranty apply or will WIKA assume any liability for use above these temperatures. Per ASME B40.3, plain glass windows must not be used on filled thermometers due to expansion of fill fluid and potential lens breakage. Note: for stem lengths over 24"- consult factory.

Thermowells are recommended for pressure, corrosive, fluid or high velocity applications.

Bimetal Thermometers

Type TI.1005

- **Small Utility**
- **Pocket Test Thermometer**
- **$\pm 1\%$ of Span Accuracy**



Type TI.1005 is a bimetal dial thermometer requiring no power to deliver its quick, accurate readings. The 1" dial is easy to read. Stem length is 5". Thermometer includes pocket case which can be used to hold the stem.

Standard Features

- **Scale:** As indicated
- **Range:** (°F); As indicated
- **Window:** Lexan
- **Connection:** Plain, $\frac{7}{16}$ " hex hub adjustment
- **Reset:** Yes; $\frac{7}{16}$ " hex hub adjustment
- **Stem diameter:** .142"
- **Accuracy:** $\pm 1\%$ of full range span (ASME B40.3 - Grade A)

Type	TI.1005
Stem Length	5"
1" Dial	°F scale
Part Number	Range
1005219D	-40/160°F
1005223D	0/220°F
1005216D	50/550°F

NOTE: Stock items shown in **bold, blue** print.

Datasheet: TI.1005

Bimetal Thermometers

Type TI.ST

- Surface Mount 2"
- Dual Magnet
- $\pm 2\%$ of Span Accuracy



WIKA dual magnet surface mount thermometers are problem solvers. Type TI.ST is an inexpensive, easy-to-use, accurate surface mounting thermometer, which attaches to any ferrous metal surface, giving unlimited localized temperature indication. The specially-designed bimetal sensing element and housing provide quick readings with an accuracy of $\pm 2\%$ of full scale range. These 2" dial thermometers feature steel cases, glass windows, polished aluminum dials with very legible graduations, and are available in ranges listed below. WIKA dual magnet mount surface thermometers are the ideal choice for ovens, boilers, process lines, motors, generators, or anywhere a temporary or permanent surface temperature is to be measured.

Standard Features

- Dial: 2"
- Depth: $\frac{1}{2}$ "
- Accuracy: $\pm 2\%$ of full range span
- Reset: No

Type	TI.ST
2" Dial	$^{\circ}\text{F}$ scale
Part Number	Range
ST206MW	0/250 $^{\circ}\text{F}$
ST228MW	0/500 $^{\circ}\text{F}$
2" Dial	$^{\circ}\text{C}$ scale
Part Number	Range
ST106MW	-20/120 $^{\circ}\text{C}$
ST101MW	-70/70 $^{\circ}\text{C}$

NOTE: Stock items shown in **bold, blue** print.

Please consult factory for other temperature ranges. Minimum order quantity may apply.



Back View



Side View

Datasheet: [TI.ST](#)

Bimetal Thermometers

Type TI.T20/TI.T17

- Thin Stem Lab Thermometer
- .150" Diameter Stem
- TI.T20-2" Dial
- TI.T17-1 3/4" Dial

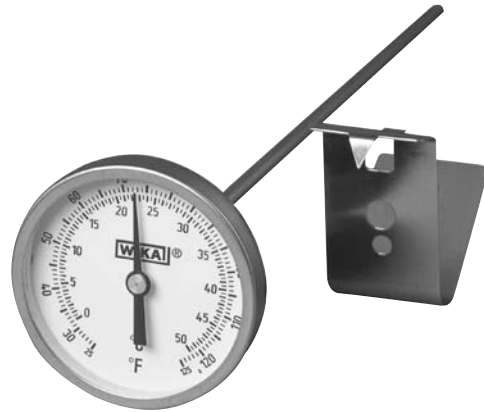

Count on WIKA laboratory/thin stem thermometers to deliver fast, extremely accurate readings. These thermometers include beaker clip and reset feature on plain connections only. No external adjustment available on threaded connections. All Type TI.T20 bimetal thermometers carry a 1-year warranty.

Standard Features

- **Case:** 304 stainless steel
- **Dial:** Heavy gauge aluminum with white matte finish
- **Window:** Fully gasketed glass standard; Lexan available
- **Reset:** $\frac{7}{16}$ " hex hub adjustable (not available with threaded connection)
- **Hermetic Seal:** Per ASME B40.3; guaranteed not to fog up
- **Stem:** 0.150" diameter; 304 stainless steel, TIG welded at tip and case connection
- **Dampening:** To minimize pointer oscillation
- **Over Range:** Temporary over or under range tolerance of 50% of scale up to 500°F (260°C)
- **Accuracy:** $\pm 1\%$ of full range span Grade A per ASME B40.3
- **Connection:** Plain, $\frac{7}{16}$ " hex hub with no threads
- **Stem Lengths:** 5", 8", 12", 18"
- **Stem Diameter:** .150"
- **External Reset:** Adjustable on plain connection only
- **Shipping Weight:** Stem length 2.5" - 9" = 4oz.**
(**weights of individual thermometers)

[Datasheet: T17_TIT20](#)

Sample Part Number: T20 050 2 24 D0 G 0 S C

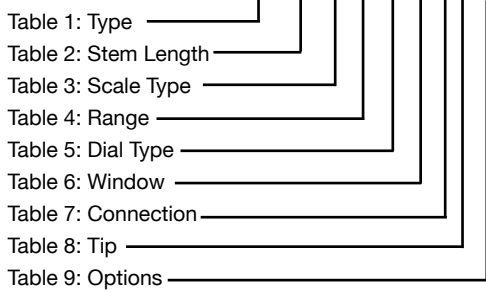

Description: T20050224D0G0SC specifies a 2" lab thermometer, 5" stem, 0/220°F only, WIKA logo, glass lens, plain connection, sharp tip, clip.

Table 1 & 2- Type & Stem Length

Type T1.T17 -1¾" Back Connected						
Stem length	2.5"	5"	8"	12"	15"	18"
Code	025	050	080	120	150	180

Type T1.T20- 2" Back Connected						
Code	025	050	080	120	150	180
Code	025	050	080	120	150	180

Table 3- Scale Type

Code	0	1	2
	Dual Scale °F & °C	°C Only	°F Only

Table 4- Standard Ranges

Code	Description (Dual scale)	°C only	°F only
*03	25/125°F & -5/50°C	0/50°C	25/125°F
04	0/140°F & -20/60°C	N/A	0/140°F
05	0/200°F & -15/90°C	0/100°C	0/200°F
08	50/300°F & 10/150°C	0/150°C	50/300°F
10	50/500°F & 10/260°C	0/250°C	50/500°F
11	150/750°F & 65/400°C	0/300°C	150/750°F
19	-40/160°F & -40/70°C	-40/70°C	-40/160°F
24	0/220°F & -10/110°C	-10/110°C	0/220°F
33	N/A	N/A	-100/100°F
34	0/180°F & -18/82°C	-18/82°C	0/180°F

*3" minimum stem length

Table 5- Dial Type

Code	Description
D0	WIKAL standard

Table 6- Window

Code	Description
G	Glass
L	Lexan

Table 7-Connection

Code	Description
0	Plain
1	1/8" NPT*
2	1/4" NPT*

*No external adjustment

Table 8- Tip

Code	Description
S	Sharp
B	Blunt

Table 9- Options

Code	Description
C	Beaker clip
0	None

Bimetal Thermometers

Type TI.20

- OEM Industrial Thermometer
- Easy-Read 2" Dial
- Back Connected



Type TI.20 thermometers are high-quality, economical thermometers designed for limited space and OEM applications. All Type TI.20 bimetal thermometers carry a 1-year warranty.

Standard Features

- **Case:** 304 stainless steel
- **Dial:** Anti-parallax or flat dial, heavy gauge aluminum with white matte finish
- **Window:** Fully gasketed glass; Lexan available
- **Reset:** N/A
- **Hermetic Seal:** Per ASME B40.3
- **Stem:** ¼" diameter; 304 stainless steel, TIG welded at tip and case connection
- **Dampening:** Inert gel to minimize pointer oscillation.
- **Over Range:** Temporary over or under range tolerance of 50% of scale up to 500°F (260°C)
- **Accuracy:** ±1% of full range span per Grade A, ASME B40.3
- **Connection:** ¼" NPT, 304 stainless steel
- **Stem Lengths:** 2½" to 24"
- **Shipping Weight:** Stem length 2½" - 9" = 6oz.**
(**weights of individual thermometers)

Note: Silicone fill not available. Thermowells are recommended for pressure, corrosive, fluid or high velocity applications.

Type TI.20 2" Dual Scale

Process Conn.	¼" NPT, Back
Stem Length	2½"
Temperature Ranges (°F &°C)	0/250 °F &°C
Part Number	20025D006G2

Stem lengths are available from 2½" to 24". Ranges from -100°F (-70°C) to 1000°F (550°C) are available. Additional options available; see pages 225-226.

For additional ordering information, refer to pages 383, 384

Bimetal Thermometers

Type TI.30/TI.50

- **Process Grade Resettable**
- **Hermetically Sealed**
- **Back Connected with Reset**



WIKA bimetal thermometers are ideal for most rugged industrial temperature measurement applications. The hermetically-sealed case offers protection from weather and dust, and is guaranteed against fogging up. WIKA Type TI.30 and TI.50 thermometers are guaranteed for 7 years.

Standard Features

- **Case:** 304 stainless steel
- **Dial:** Anti-Parallax, heavy gauge aluminum with white matte finish
- **External Reset:** Slotted hex adjustment
- **Window:** Fully gasketed glass
- **Hermetic Seal:** Per ASME B40.3
- **Stem:** 1/4" diameter; 304 stainless steel, TIG welded at tip and case connection. 3/8" diameter available
- **Dampening:** Inert gel to minimize pointer oscillation.
- **Over Range:** Temporary over or under range tolerance of 50% of scale up to 500°F (260°C)
- **Accuracy:** ±1% full range span (ASME B40.3 Standard)
- **Shipping Weight:**
Type 30: stem length 2 1/2"-9"=12oz.
Type 50: stem length 2 1/2"-9"=1lb.8oz.
(weights of individual thermometers)

Available Options

Stem Lengths: (in inches) 2 1/2, 4, 6, 9, 12, 15, 18, 24, up to 72"
Silicone Fill, Custom Dials, Min-Max Pointer, Union Locknut, Dampened Movement
Window: Lexan, Acrylic, Shatterproof

Type TI.30 - 3" Single Scale

Connection	Back				
Process Conn.	1/2" NPT				
Stem Length	2 1/2"	4"	6"	9"	12"
Temperature Ranges (Fahrenheit)					
-40/120 °F	30025D202G4	30040D202G4	30060D202G4	30090D202G4	30120D202G4
0/250 °F	30025D206G4	30040D206G4	30060D206G4	30090D206G4	30120D206G4
50/550 °F	30025D216G4	30040D216G4	30060D216G4	30090D216G4	30120D216G4

Type TI.30 - 3" Dual Scale

Temperature Ranges (Fahrenheit & Celsius)					
-40/120 °F & °C	30025D002G4	30040D002G4	30060D002G4	30090D002G4	30120D002G4
0/250 °F & °C	30025D006G4	30040D006G4	30060D006G4	30090D006G4	30120D006G4
50/500 °F & °C	30025D010G4	30040D010G4	30060D010G4	30090D010G4	30120D010G4

Type TI.50 - 5" Single Scale

Stem Length	2 1/2"	4"	6"	9"
Ranges (Fahrenheit)				
-40/120 °F	50025D202G4	50040D202G4	50060D202G4	50090D202G4
0/250 °F	50025D206G4	50040D206G4	50060D206G4	50090D206G4
50/550 °F	50025D216G4	50040D216G4	50060D216G4	50090D216G4

Type TI.50 - 5" Dual Scale

Ranges (Fahrenheit & Celsius)				
-40/120 °F & °C	50025D002G4	50040D002G4	50060D002G4	50090D002G4
0/250 °F & °C	50025D006G4	50040D006G4	50060D006G4	50090D006G4
50/500 °F & °C	50025D010G4	50040D010G4	50060D010G4	50090D010G4

NOTE: Stock items shown in **bold, blue** print.

For additional ordering information, refer to pages 383, 384

Datasheet: [TI.30](#), [TI.50](#)

Bimetal Thermometers

Type TI.31/TI.51



- **Process Grade Resettable**
- **Hermetically Sealed**
- **Bottom Connected with Reset**

WIKAI TI.31 and TI.51 bimetal thermometers offer the same features as the TI.30 and TI.50, with a fixed lower mount (bottom) connection. The hermetically-sealed case offers protection from weather and dust, and is guaranteed against fogging up. The TI.31 and TI.51 have a 7 year guarantee.

Standard Features

- **Case:** 304 stainless steel
- **Dial:** Anti-parallax, heavy gauge aluminum with white matte finish.
- **External Reset:** Slotted hex adjustment
- **Window:** Fully gasketed glass standard
- **Hermetic Seal:** Per ASME B40.3
- **Stem:** 1/4" diameter; 304 stainless steel, TIG welded at tip and case connection. 3/8" diameter available
- **Dampening:** Inert gel to minimize pointer oscillation.
- **Over Range:** Temporary over or under range tolerance of 50% of scale up to 500°F (260°C)
- **Accuracy:** ±1% full range span per ASME B40.3
- **Shipping Weight:**
 Type 31: stem length 2 1/2" - 9" = 12oz.**
 Type 51: stem length 2 1/2" - 9" = 1lb. 10oz.**
 (**weights of individual thermometers)

Type	TI.31 3" Single Scale		
Connection	Lower		
Process Conn.	1/2" NPT		
Stem Length	2 1/2"	4"	6"
Temperature Ranges (Fahrenheit)			
-40/120 °F	31025D202G4	31040D202G4	31060D202G4
0/250 °F	31025D206G4	31040D206G4	31060D206G4
50/550 °F	31025D216G4	31040D216G4	31060D216G4

Note: TI.51, 5" dial thermometer also available.
 Consult factory for details.

For additional ordering information, refer to pages 383, 384

Available Options:

Stem Lengths: (In Inches) 2 1/2, 4, 6, 9, 12, 15, 18, 24, up to 72"
 Silicone Fill, Custom Dials, Min-Max Pointer, Union Locknut, Union Connection
 Window: Lexan, Acrylic, Shatterproof,
 Sharp tip, Dampened Movement
 RS= Ride side connection location
 LS= Left side connection location
 TS= Top side connection location

Datasheets: TI.31, TI.51

Bimetal Thermometers

Type TI.32/TI.52



- **Process Grade**
- **Any Angle Adjustable Dial**
- **Stainless Steel Case & Screw**

WIKA TI.32 and TI.52 bimetal thermometers are similar to TI.30 and TI.50 but with an all-angle swivel connection. The hermetically-sealed case offers protection from weather and dust, and is guaranteed against fogging up. WIKA TI.32 and TI.52 Thermometers are guaranteed for 7 years.

Standard Features

- **Case:** 304 stainless steel
 - **Dial:** Anti-parallax, heavy gauge aluminum with white matte finish
 - **External Reset:** Slotted hex adjustment
 - **Window:** Fully gasketed glass
 - **Hermetic Seal:** Per ASME B40.3
 - **Stem:** 1/4" diameter; 304 stainless steel, TIG welded at tip and case connection. 3/8" diameter available
 - **Dampening:** Inert gel to minimize pointer oscillation.
 - **Over Range:** Temporary over or under range tolerance of 50% of scale up to 500°F (260°C)
 - **Accuracy:** ±1% of full scale per ASME B40.3
 - **All Angle Case:** Rotation of 360° and stem variation of more than 180°.
 - **Shipping Weight:**
 Type 32: stem length 2 1/2" - 9" = 1lb.
 Type 52: stem length 2 1/2" - 9" = 2lbs.
 (weights of individual thermometers)
- Available Options:**
 Stem Lengths: (in inches) 2 1/2, 4, 6, 9, 12, 15, 18, 24, up to 72"
 Silicone Fill, Custom Dials, Min-Max Pointer, Union Locknut, Sharp Tip, Dampened Movement
 Union connection
 Window: Lexan, Acrylic, Shatterproof

Type	TI.32 3", Single Scale				
Connection	All Angle				
Process Conn.	1/2" NPT				
Stem Length	2 1/2"	4"	6"	9"	12"
Temperature Ranges (Fahrenheit)					
-40/120 °F	32025D202G4	32040D202G4	32060D202G4	32090D202G4	32120D202G4
0/250 °F	32025D206G4	32040D206G4	32060D206G4	32090D206G4	32120D206G4
50/550 °F	32025D216G4	32040D216G4	32060D216G4	32090D216G4	32120D216G4

Type	TI.52 5" Dual Scale				
Connection	All Angle				
Process Conn.	1/2" NPT				
Stem Length	2 1/2"	4"	6"	9"	12"
Temperature Ranges (Fahrenheit & Celsius)					
-40/120 °F & °C	52025D002G4	52040D002G4	52060D002G4	52090D002G4	52120D002G4
0/250 °F & °C	52025D006G4	52040D006G4	52060D006G4	52090D006G4	52120D006G4
50/500 °F & °C	52025D010G4	52040D010G4	52060D010G4	52090D010G4	52120D010G4

Type	TI.52 5" Single Scale				
Connection	All Angle				
Process Conn.	1/2" NPT				
Stem Length	2 1/2"	4"	6"	9"	12"
Temperature Ranges (Fahrenheit)					
-40/120 °F	52025D202G4	52040D202G4	52060D202G4	52090D202G4	52120D202G4
0/250 °F	52025D206G4	52040D206G4	52060D206G4	52090D206G4	52120D206G4
50/550°F	52025D216G4	52040D216G4	52060D216G4	52090D216G4	52120D216G4

NOTE: Stock items shown in **bold, blue** print.

For additional ordering information, refer to pages 383, 384

Datasheets: [TI.32](#), [TI.52](#)

Bimetal Thermometers

Type TI.33/TI.34 TI.53/TI.54

- Industrial Grade Thermometer
- Stainless Steel Case
- Tamper Proof



WIKAL's industrial grade bimetal dial thermometers, TI.33, 34, 53, 54 are an ideal choice where a weather-resistant, tamper-proof thermometer is needed. They are warranted for 1 year.

Standard Features

- **Case:** 304 stainless steel
- **Dial:** Anti-Parallax, heavy gauge aluminum with matte finish
- **Window:** Fully gasketed glass
- **Hermetic Seal:** Per ASME B40.3
- **Stem:** 1/4" diameter; 304 stainless steel, TIG welded at tip and case connection. 3/8" diameter available
- **Accuracy:** ±1% of full range span per Grade A, ASME B40.3
- **Over Range:** Temporary over or under range tolerance of 50% of scale up to 500°F (260°C)
- **Shipping Weight:**
Type 33 & 34: stem length 2 1/2" - 9" = 12oz.
Type 53: stem length 2 1/2" - 9" = 1lb. 8oz.
Type 54: stem length 2 1/2" - 9" = 12oz.
(*weights of individual thermometers)

Type	TI. 33 3" Single Scale			
Connection	Back			
Process Conn.	1/2" NPT			
Stem Length	2 1/2"	4"	6"	9"
Temperature Ranges (Fahrenheit)				
0/250 °F	33025D206G4	33040D206G4	33060D206G4	33090D206G4
50/550 °F	33025D216G4	33040D216G4	33060D216G4	33090D216G4

Type Descriptions

- Type 33 (Type TI.33) = 3" back connection
- Type 34 (Type TI.34) = 3" bottom connection
- Type 53 (Type TI.53) = 5" back connection
- Type 54 (Type TI.54) = 5" bottom connection

For additional ordering information, refer to pages 383, 384

Note: Silicone-filled, Dampened Movement, min/max pointer, dry with plug, .375 stem and 316 wetted parts not available

Available Options

Stem lengths from 2 1/2" to 24". Ranges from -100°F (-70°C) to 1000°F (550°C).
Special Ranges, Custom Dials, Stems, Connections and Windows.
Window: Lexan, Acrylic, Shatterproof
Sharp Tip

Datasheets: [TI.33](#), [TI.34](#)
[TI.53](#), [TI.54](#)

Ordering Bimetal Thermometers

Sample Part Number: 30 060 D 0 01 G 4 XX

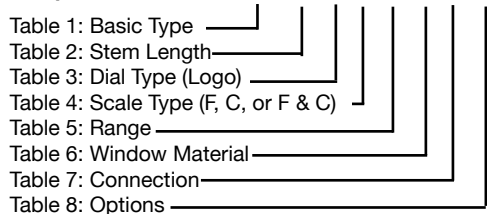

Table 1- Basic Type

Process Grade- Resettable		Industrial Grade- Non-Resettable	
Type	Description	Type	Description
30	3" Back Connected	20	2" Back Connected
31	3" Bottom Connected	33	3" Back Connected
32	3" Adjustable Angle	34	3" Bottom Connected
50	5" Back Connected	53	5" Back Connected
51	5" Bottom Connected	54	5" Bottom Connected
52	5" Adjustable Angle		

Stem lengths above 24" are not available in non-resettable models

Table 2- Stem Length - (specify as XX.X" with no decimal point, see "code")

Stem Length	2.5 - 9"	12"	15"	18"	24"	30"	36"	42"	48"	54"	60"	66"	72"
Code	025	120	150	180	240	300	360	420	480	540	600	660	720

Table 3- Dial Type

Code	Description
D	WIKA standard
X	Special

Table 4 - Scale Type

Code	Description
0	Dual scale Fahrenheit and Celsius
1	Single scale Celsius only
2	Single scale Fahrenheit only

Table 5 - Range

Code	°F Range	Figure Int.	Div.	Dual Scale			Single Scale	
				°C range	Figure Int.	Div.	°F Range	°C Range
01 ⁽³⁾	-100/150°F	20°	2°	-70/70°C	10°	1°	-100/150°F	-70/70°C
13	-80/120°F	20°	2°	-60/50°C	10°	1°	-80/120°F	-60/50°C
02	-40/120°F	20°	2°	-40/50°C	10°	1°	-40/120°F	-50/50°C
14	-20/120°F	20°	2°	-30/50°C	10°	1°	-20/120°F	-30/50°C
19	-40/160°F	20°	2°	-40/70°	10°	1°	-40/160°F	-40/70°C
23 ⁽¹⁾	0/100°F	10°	1°	-20/40°C	5°	½°	0/100°F	-20/40°C
03 ⁽¹⁾	25/125°F	10°	1°	-5/50°C	5°	½°	25/125°F	0/50°C
15 ⁽¹⁾	30/130°F	10°	1°	0/55°C	5°	½°	30/130°F	0/55°C
04	0/140°F	10°	1°	-20/60°C	5°	½°	0/140°F	-20/60°C
05	0/200°F	20°	2°	-15/90°C	10°	1°	0/200°F	0/100°C
06	0/250°F	20°	2°	-20/120°C	10°	1°	0/250°F	-20/120°C
07	20/240°F	20°	2°	-5/115°C	10°	1°	20/240°F	-10/110°C
08	50/300°F	20°	2°	10°/150°C	10°	1°	50/300°F	0/150°C
09	50/400°F	50°	5°	10/200°C	20°	2°	50/400°F	0/200°C
10	50/500°F	50°	5°	10/260°C	20°	2°	50/500°F	0/250°~
16 ⁽³⁾	50/550°F	50°	5°	10/290°C	20°	2°	50/550°F	10/290°C
17 ⁽³⁾	0/600°F	100°	10°	-20/315°C	50°	5°	0/600°F	-20/315°C
11 ⁽³⁾	150/750°F	100°	10°	65/400°C	50°	5°	150/750°F	0/300°C
18 ⁽³⁾	100/800°F	100°	10°	40/425°C	50°	5°	100/800°F	0/450°C
12 ^(2, 3)	200/1000°F	100°	10°	100/540°C	50°	5°	200/1000°F	100/550°C

⁽¹⁾ Not available with 2½" stem on Models 31, 32, 34, 51, 52, 54

⁽²⁾ Not recommended for continued use over 800°F

⁽³⁾ Silicone fill not available

Ordering Bimetal Thermometers

Table 6 - Window Material

Code	Description
A	Acrylic plastic (standard w/Silicone fill)
G ¹⁾	Plain glass (standard)
L	Lexan® (not available on 5" dial)
S ¹⁾	Shatterproof safety glass (3" & 5" dials only)

1) not available with silicone fill

Table 7 - Connection

Code	Description
0	Plain (unthreaded)
1	1/8" NPT (Model 20 only)
2	1/4" NPT (standard on Model 20)
3	3/8" NPT (N/A Models 32, 31,34, 52, 54)
4	1/2" NPT (standard on 3" & 5" Models)
5	G 1/2" B (Models 30 & 50 only)
7	1/2" NPT Adjustable union (Models 32 & 52 only)

Table 8 - Options (3" and 5" Models)

Code	Description
DM	Dampened Movement
SF	Silicone filled- (Models 30,31,32,50,51**,52 only)
ST	Sharp tip
MM	Min/Max pointer (Models 30 & 50 only)
LS	Left side connection (Models 31,51 only)
RS	Right side connection (Models 31,51 only)
TS	Top connection (Models 31, 51 only)
DF ²⁾	Dry with plug (30, 31, 32, 50, 51, 52)

2) Prepares unit for liquid case filling and shipped dry

Sample Part Number: 30 060 D 0 01 G 4 XX

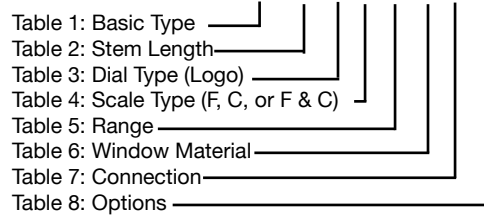

Certificates

Description	Part Number
Certificate of Compliance	N/A
NIST Factory Certificate of Accuracy	N/A

.375 Stem Diameter Upgrade Option

Code	Description
HA ⁽⁴⁾	Full length
HD ⁽⁴⁾	Reduced tip
HS ⁽⁴⁾	Reduced w/sharp tip

316 Stainless Steel Wetted Parts Upgrade available on .250 Stem Diameter

Code	Description
SS ⁽⁴⁾	316 Wetted Parts

⁽⁴⁾ only available with Process Grade types (30, 31, 32, 50, 51, 52)

Accessories

Part Number	Description
TA600-0111	1/2" Union Locknut
TA800-0T85	T-85 Conv Kit
TA800-0020	1/2" NPT Duct Flg.
N/A	SS Tag
2256045	5.3 oz. tube heat transfer compound for use in thermowells

ABBREVIATIONS

N/A - this option is not available
 STD - this option comes standard

Bimetal Thermometer Options



DAMPENED MOVEMENT

Dampened Movement

Engineered solution providing benefits of case fill in a dry configuration. This silicone-free option provides dampening in tough environments at all available temperature ranges. Available in all process grade models.

T-85 Thermowell Conversion Kit

This conversion kit offers an easy, inexpensive way to install a WIKA bimetal thermometer in a glass industrial thermometer's thermowell. For more information, please consult factory. To order, specify part number **TA800-0T85**.

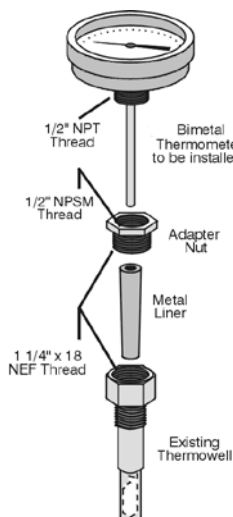

Adjustable Union Connection

The WIKA Adjustable Union Connection allows for the installation of a Type 32 or 52 adjustable angle thermometer without rotating the case. Ideal for use in a confined space.

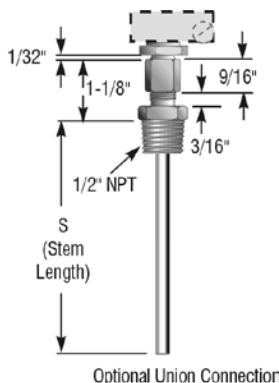

Left, Right or Top Connection

All WIKA 3" and 5" Bottom Connected thermometers are available with the connection oriented to the left, right or top. Please see "How to Order" on next page for this option.

Not Shown

- Heavy duty 3/8" stems and 3/8" stems with 2 1/2" x 1/4" OD sensitive portion available
- Thermometers may be ordered with sharp tips for piercing media to be measured
- 316 stainless steel wetted parts are available
- 1/2" NPT duct flange
- Acrylic, Lexan, shatterproof and glass windows
- Stainless steel tags are available options
- Silicone Fill
- Certificates of Conformance, Origin and Calibration available
- Please see these options on Table 8 of "Ordering Bimetal Thermometers" on pages 391, 392.
- Other options are available. Please consult factory.

Union Lock Nut

The WIKA Union Lock Nut provides a simple and inexpensive means to mount WIKA bimetal thermometers with 1/2" NPT so that the dial is oriented for proper viewing. For more information, please consult factory. To order, specify part number **TA600-0111**.

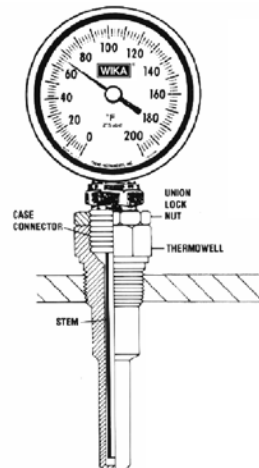

Maximum or Minimum Indicating Pointer

This option allows operator to view what the highest or lowest temperature has been in the process. High vibration environments are not recommended.



Digital Thermometers

Digital Thermometers

Type TI.1006DW

- **Small Utility**
- **Digital Readout**
- **Pocket Thermometer**



The Type TI.1006DW is a water-resistant, impact-resistant digital pocket thermometer offering both Fahrenheit and Celsius readings, with a unique "data hold" feature that "remembers" the last reading. Range is from -40° to 300°F and -40° to 150°C and the battery is included.

Standard Features

- **Scale:** As indicated
- **Range:** °F & °C
- **Stem Length:** 2½"
- **Stem Diameter:** .157"
- **Accuracy:** ± 1% of full range span

Type	TI1006DW
Stem length	2.5"
Range (Fahrenheit & Celsius)	
-40/300°F & °C	

NOTE: Stock items shown in **bold, blue** print.

Digital Thermometers

Type TI.80/TI.82

- Solar Digital Thermometer
- Easy-to-Read
- R & D Applications



WIKA's solar-powered digital thermometers are ideal for power utilities, petrochemical, and quality control applications, where exact readings are required. TI.80 and TI.82 offers easy-to-read digital temperature in single-degree increments in either Fahrenheit or Celsius scales. TI.80 has a center back mount, while the TI.82 has an adjustable angle, hermetically-sealed case.

Standard Features

- **Case:** 304 stainless steel
- **Stem:** 304 stainless steel, lengths from 1" to 24"
- **Window:** Glass standard, acrylic available
- **Connection:** 1/2" NPT, others available
- **Sensor System:** Ceramic thermistor requiring lighting of only 35 LUX to operate the 3-volt solar cell. The circuitry offers a fast 15-second update time and accuracy to within 1% of scale. A patented safety circuit prevents false readings.
- **Accuracy:** ± 1% of full range span

Note: TI.80/TI.82 are made to order

Just-Rite Adjustable Angle		
	Range -50° to 300°F	Range -50° to 150°C
Stem Length	Part Number	Part Number
2 1/2"	82025D2G4	82025D1G4
4"	82040D2G4	82040D1G4
6"	82060D2G4	82060D1G4
9"	82090D2G4	82090D1G4
12"	82120D2G4	82120D1G4
15"	82150D2G4	82150D1G4
18"	82180D2G4	82180D1G4
24"	82240D2G4	82240D1G4

Back Connected		
	Range -50° to 300°F	Range -50° to 150°C
Stem Length	Part Number	Part Number
2 1/2"	80025D2G4	80025D1G4
4"	80040D2G4	80040D1G4
6"	80060D2G4	80060D1G4
9"	80090D2G4	80090D1G4
12"	80120D2G4	80120D1G4
15"	80150D2G4	80150D1G4
18"	80180D2G4	80180D1G4
24"	80240D2G4	80240D1G4

Options		
	Code	Description
Connection	0	Plain
	2	1/4" NPT
	3	3/8" NPT (80 only)
Window	A	Acrylic
Accessories	ST	Sharp tip
	SS	316 ss wetted parts
Stem	HD	3/8" dia. stem w/ 2 1/2" L x 1/4" dia tip
	HS	3/8" dia. stem w/ 2 1/2" L x 1/4" dia. sharp tip

Datasheet: [TI.80/TI.82](#)

Twin-Temp Bimetal Thermometers with Thermocouple/RTD Output

Bimetal Thermometers with Thermocouple/RTD Output

Type TT.30, TT.32
TT.50, TT.52

- Twin-Temp with Reset
- Two Temperature Sensors
- Easy Readability



The Twin-Temp thermometer combines the convenience, simplicity, and self-powered actuation of a bimetal thermometer and data acquisition capabilities of a thermocouple or RTD electrical output. With standards traceable to the NIST, the Twin-Temp offers simplified calibration for ISO 9001 compliance and other statistical process control requirements. It is ideal in applications requiring quick and easy readability at the point of process, while still affording a means of electronic data acquisition and digital panel remote read-out. The Twin-Temp puts two temperature sensors to work at one location.

Standard Features

- **Case and Bezel:** 304 stainless steel
- **Case:** All angle or Back connected
- **Dial Size:** 3" or 5"
- **Process Connection:** ½" NPT standard
- **External Reset:** Slotted hex head, fully gasketed
- **Window:** Glass, fully gasketed
- **Hermetic Seal:** Per ASME B40.3
- **Stem:** 304 stainless steel, TIG welded at tip and case connector to prevent leakage.
¼" diameter standard, lengths available from 2½" to 48" for Thermocouple, 4" to 48" for RTD.
- **Over Range:** Maximum exposure 500°F
- **Thermocouple:** Type K grounded junction thermo couple standard. Types J, E, & T available
- **RTD:** 100-Ohm thin film Platinum DIN Curve (.00385 Ohm/Ohm/°C), 3 wire standard
- **Accuracy:** ± 1% of full range span
- **Warranty:** 1 year
- **Wiring:** Twin-Temp (RTD): Red- terminal 1, Green-terminal 2, Black- terminal 3 Twin-Temp (T/C): Negative- Red always, Positive- Colored (depends on t/c type)

Note: Silicone fill not available

Datasheets: [TT.30](#), [TT.32](#), [TT.50](#), [TT.52](#)

Ordering Twin-Temp Thermometers

Type TT.30, TT.32, TT.50, TT.52

HOW TO ORDER:

Select the appropriate codes and combine to complete thermometer part number.

Sample Part Number: 30 060 D 0 01 G 4 R1 A R

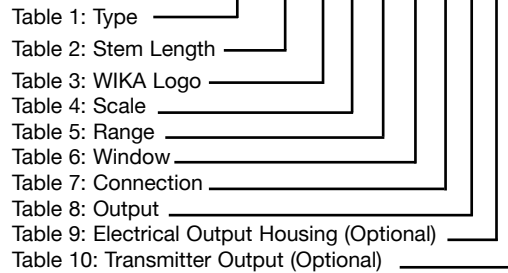

Table 1 - Type

Code	Description
30	3" Back connected (with reset)
32	3" All angle (with reset)
50	5" Back connected (with reset)
52	5" All angle (with reset)

Table 2 - Stem Length

(Pick stem length from either thermocouple or RTD table)

Code	Description
XXX	Length in inches with one decimal place (XX.X) RTD available only in 4" to 48" (040-480) stem length. Thermocouple available 2½"-48" (025-480).

Thermocouples- Types J, K, E, T Grounded Thermocouple Output (consult factory for ungrounded)

Stem Length	2.5	4	6	9	12	15	18	24	30	36	42	48
Code	025	040	060	090	120	150	180	240	300	360	420	480

Note: Thermocouple junction is welded to tip of stem

or

100 Ohm RTD-Output

Stem Length	2.5	4	6	9	12	15	18	24	30	36	42	48
Code	N/A	040	060	090	120	150	180	240	300	360	420	480

Note: RTD is placed in stem above bimetal helix (requires minimum 3½" insertion)

Table 3 - Dial Type

Code	Description
D	WIKA standard
X	Special

Table 4 - Scale Type

Code	Description
0	Dual scale Fahrenheit and Celsius
1	Single scale Celsius only
2	Single scale Fahrenheit only

ABBREVIATIONS

N/A - this option is not available

Table 5 - Ranges

Code	Description	0	1	2
Code		Dual Scale °F & °C	Celsius Only	Fahrenheit Only
02*	-40/120°F & -40/50°C	-50/50°C	-	-40/120°F
03*	25/125°F & -5/50°C	0/50°C	-	25/125°F
04*	0/140°F & -20/60°C	0/140°F	-	-
05	0/200°F & -15/90°C	0/100°C	-	0/200°F
06	0/250°F & -20/120°C	-20/120°C	-	0/250°F
07	20/240°F & -5/115°C	-	-	20/240°F
08	50/300°F & 10/150°C	0/150°C	-	50/300°F
09	50/400°F & 10/200°C	0/200°C	-	50/400°F
10	50/500°F & 10/260°C	0/250°C	-	50/500°F
16	50/550°F & 10/260°C	-	N/A	50/550°F

* Not available with 2½" stem

Ordering Twin-Temp Thermometers continued

Table 6 - Window

Code	Description
G	Plain Glass
A	Acrylic
L	Lexan®
S	Shatterproof

Table 7 - Connection

Code	Description
2	¼" NPT
4	½" NPT

Choose an electrical output configuration from either the left column only or right column only.

Table 8 - Electrical Output & Connection Type Selections

Order from this column for direct thermocouple (female plug) or RTD (mini 3-pos terminal block) output only; **will not accept transmitter or enclosure head options.**

Electrical weatherproof housing connection is A 7/8-20 UNEF.
 Thermocouple= female plug
 RTD= 3-wire mini-terminal

Code	Description
TJ	Thermocouple output, Type J (female plug)
TK	Thermocouple output, Type K (female plug)
TE	Thermocouple output, Type E (female plug)
TT	Thermocouple output, Type T (female plug)
RA	100 ohm RTD output, 3 wire (terminal block)

Table 9 - Electrical Output Housing Options
(Match code to Table 8 output)

For non-transmitter units. Plug-in (RTD output wire-in) field connections only. (Match code to output selection in Table 8)

Code	Description
X	None
J	Straight barrel weather proof housing (7/8-20 UNEF) & plug
K	Straight barrel weather proof housing (7/8-20 UNEF) & plug
E	Straight barrel weather proof housing (7/8-20 UNEF) & plug
T	Straight barrel weather proof housing (7/8-20 UNEF) & plug
R	Straight barrel weather proof housing (7/8-20 UNEF)

Table 10 - Transmitter Output

For non-transmitter equipped units.

Plug-in (RTD output wire-in) field connection only.

Code	Description
X	None (mandatory on all non-transmitter models) (must use this code "X" for all TJ/TK/TE/TT/RA from Table 8)

Table 8 - Electrical Output & Connection Type Selections

Order from this column for unit with lead wires for both thermocouple or RTD output; **will accept enclosure head for transmitter or terminal block housing options.**

Electrical enclosure connection is A ½" NPT.
 Thermocouple or RTD is 6" flying lead wire.

Code	Description
*J1	Thermocouple output, Type J
K1	Thermocouple output, Type K
E1	Thermocouple output, Type E
T1	Thermocouple output, Type T
R1	100 ohm RTD output, 3 wire

* Longer lead wires available in 6" lead wire increments

Table 9 - Electrical Output Housing Options

For transmitter-equipped units.

Code	Description
X	None
A	*Standard aluminum head enclosure
H	*Exp. Proof Head

*(½" NPT Twin-Temp x ¾" NPT Field Conn.)

Table 10 - Transmitter Output

For transmitter equipped units.

Code	Description
X	None (mandatory on all non-transmitter models; must use this code "X" for all TJ/TE/TT/RA from Table 8)
T	^{1,2} 4-20mA transmitter for all thermocouple output
R	^{2,3} 4-20mA transmitter for all "R1" RTD output (from table 8)
B	³ Terminal Block (for field wiring termination (when transmitter not used)

¹only compatible with codes J1/K1/E1/T1;

²only compatible with code R1

³must use code A or H from table 9 for enclosure

Possible combinations for Tables 6 & 10:

XX/JX/KX/EX/TX/RX

AX/AT/AR/AB

Twin-Temp Configurations

(cont.)

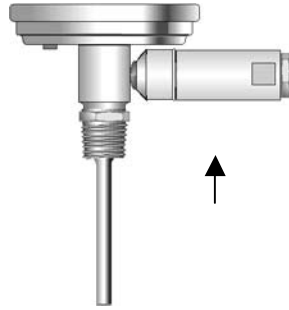

1. Weatherproof Housing and Plug

$\frac{7}{8}$ -20 UNEF threaded barrel with bushing and compression nut provide environmental protection to thermocouple/RTD connection. (Order code J,K,E,T or R from Table 9)

2. $\frac{1}{2}$ " NPT electrical connection with lead wire

Available in thermocouple or RTD. This allows site installation using other enclosures or piping systems. (Order code J1, K1, E1, T1, or R1 from Table 8)

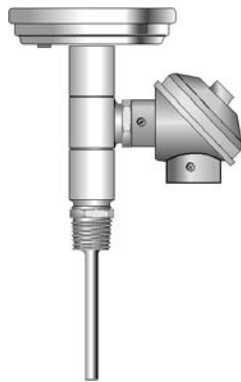
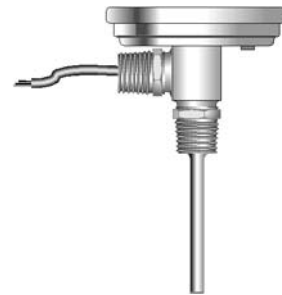

3. Enclosure Head

A protective enclosure threads onto the optional $\frac{1}{2}$ " NPT electrical connection. The housing protects electrical connections from the environment. Houses a 4-20 mA transmitter or terminal block. Aluminum housing is standard. (Order code A from Table 9).

4. Terminal Block

Provides a connection point for the thermocouple or RTD. Mounts to thermocouple head with two screws. Requires lead-wire output connection (order code J1/K1/E1/T1/R1 from Table 8) and aluminum head enclosure (order code A from Table 9).



5. T-23 Thermocouple or T-24- RTD, 4-20 mA Transmitter

Provides a clean 4-20 mA signal to control room, data acquisition equipment, panel readout, etc. Requires lead-wire output connection (order code J1/K1/E1/T1/R1 from Table 8) and aluminum head enclosure (order code from Table 9)

Spare Parts

Description	Part Number
Std. Aluminum Head	102-02
Terminal Block	2246228
¹⁾ Thermocouple Transmitter	4310853
¹⁾ RTD Transmitter	4363295
Weatherproof Housing	TA6S0-0608

¹⁾ When order separate of a twin-temp, range must be specified

Twin-Temp Configurations

Examples

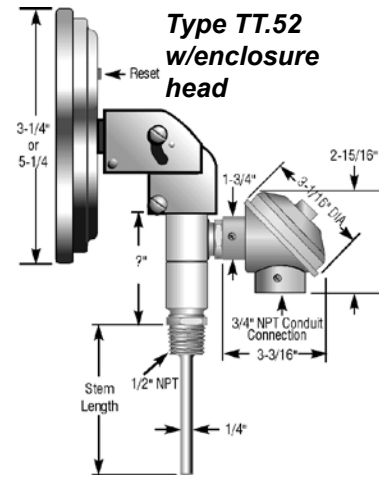
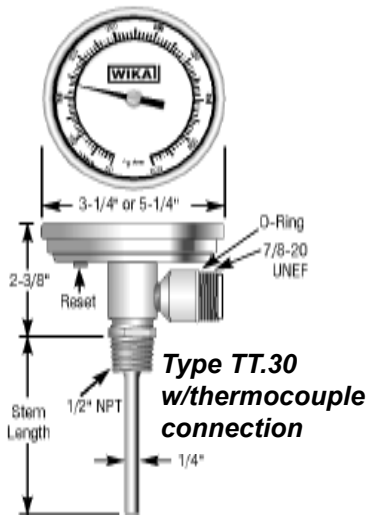
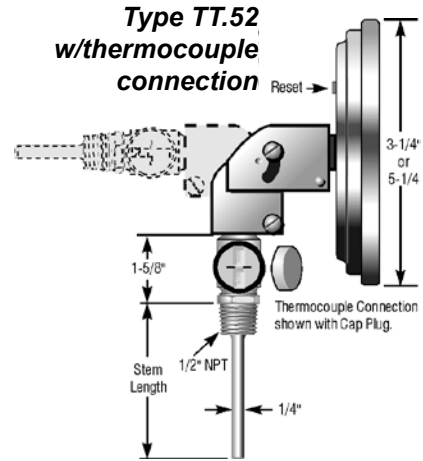
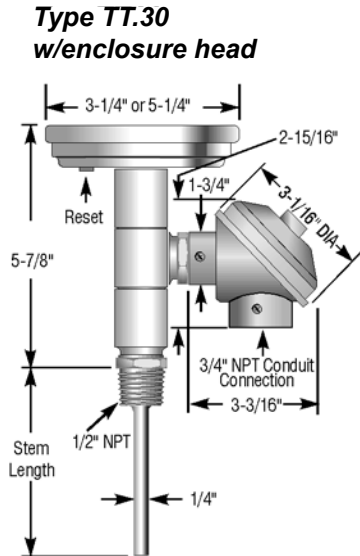

**Type TT.30
w/thermocouple Plug-in**

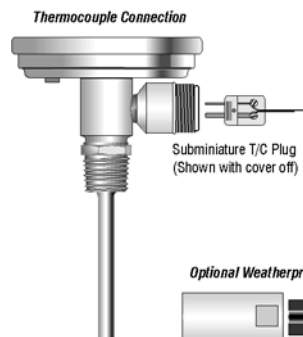

**Type TT.30
w/RTD terminal block**

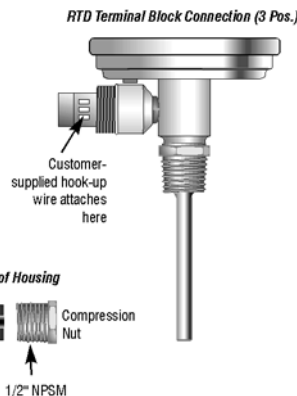

Solar Digital Thermometers with Thermocouple/RTD Output

Type TT.80, TT.82

- **Two Sensors in One Location**
- **Convenient Digital Display Solar Powered (35 Lux)**
- **Thermocouple or RTD Available**



This unique thermometer has the convenience of a LCD digital output and the data acquisition capabilities of a thermocouple or RTD electrical output in one process location.

Standard Features

- **Case and Bezel:** 304 stainless steel
- **Case:** All Angle or Back Connected
- **Dial Size:** 3"
- **Process Connection:** ½" NPT Standard
- **Window:** Glass, fully gasketed
- **Hermetic Seal:** Per ASME B40.3
- **Stem:** 304 stainless steel, TIG welded at tip and case connector to prevent leakage. ¼" diameter standard, lengths available from 2½" to 24".
- **Thermocouple:** Type K grounded junction thermocouple standard. Types J, E, T available
- **RTD:** 100-Ohm thin film Platinum DIN Curve (.00385 Ohm/Ohm/°C), 3 wire standard
- **Accuracy:** ± 1% of full range span
- **Warranty:** 1 year
- **Wiring:** Twin-Temp (RTD): Red- terminal 1, Green-terminal 2, Black- terminal 3 Twin-Temp (T/C): Negative- Red always, Positive- Colored (depends on t/c type)

Note: Silicone fill not available

Datasheets: [TT.80](#), [TT.82](#)

Ordering Twin-Temp Thermometers

Type TT.80, TT.82

Sample Part Number: 80 040 D 1 G 4 R1 A R

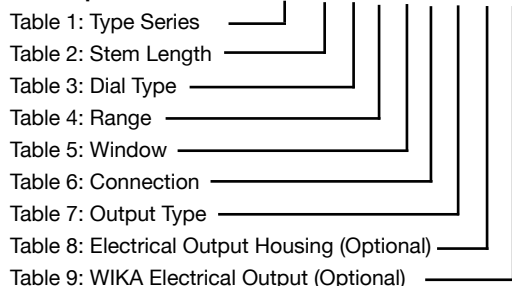

Table 1 - Type

Code	Description
80	3" Back connected (with reset)
82	3" All angle (with reset)

Table 6- Process Connection

Code	Description
4	1/2" NPT

Table 2 - Stem Length

Code	Description
025	2 1/2"
040	4"
060	6"
090	9"
120	12"
150	15"
180	18"
240	24"

Table 7 -Electrical Output

Code	Description
J1	Thermocouple output, Type J
K1	Thermocouple output, Type K
E1	Thermocouple output, Type E
T1	Thermocouple output, Type T
R1	100 Ohm RTD output, 3 wire

*Longer lead wires available. Consult factory.

Table 3 - Dial Type

Code	Description
D	WIKA Standard

Table 8 - Electrical Output Housing Options

For transmitter equipped units.

Code	Description
X	None
A	Standard aluminum head enclosure

Table 4 - Ranges

Code	Description
1	-50/300F
2	-50/150C

Table 9 - Transmitter Output

Code	Description
X	None (mandatory on all non-transmitter models)
T	4-20mA transmitter for all thermocouple output
R	4-20mA transmitter for all "R1" RTD output (see output table)
B	Terminal block (for field wiring termination)

Table 5 - Window Material

Code	Description
G	Plain glass
A	Acrylic

Gas Actuated Thermometers

Gas Actuated Thermometers Operating & Installation

Gas actuated thermometers fall within "Class IV, gas-filled with absorbent" definition. They use a thermal system filled with gas and an adsorbent (such as activated granular carbon) in the bulb. This technology allows for a significantly reduced bulb size. WIKA gas actuated thermometers offer extremely high accuracy, low ambient error, and extreme over-range capability. With the same small bulb diameter throughout the offered ranges, the WIKA thermometer can be installed in most existing piping and tank applications.

WIKA gas actuated thermometers provide the solution to mercury-free requirements in food processing, refrigeration, or other mercury-sensitive environments. A variety of case types, sizes and materials provides a custom made instrument for each application in ranges between -320° Fahrenheit and +1200° Fahrenheit or equivalent Celsius. Dual reading scales (F & C) are standard.

WIKA gas actuated dial thermometers are available as direct reading or remote reading with stainless steel bulbs and armored capillary. WIKA extends a one-year warranty against defects in material and workmanship on standard gas actuated dial thermometers.



Installation Guidelines: While WIKA gas actuated dial thermometers are highly accurate and rugged instruments, there are some guidelines that should be followed in their application and installation. Consideration must be given to the measured medium. Is it corrosive, abrasive, turbulent, or under pressure? Can the sensing bulb be placed to give an accurate indication of the temperature?

The sensing bulb should be placed in a non-turbulent area of piping or ducting and as close the center of the flow as possible. In tanks, it should be placed in an area of the tank that will provide a good average of the temperature of the fluid contained. The bulb should be protected from corrosive or abrasive media and excessively high pressures. The usual method of protection is the use of a thermowell.

When a remote reading thermometer is installed, consideration must be given to the location of the bulb, the dial indicator, and the routing of the capillary. The capillary must be located where it will not be damaged by workers or equipment used in future maintenance. Remember that the capillary CANNOT be cut to facilitate installation or relocation.

For Installation and Use of WIKA Filled System Dial Thermometers

General: Before installing a thermometer, consideration should be given to temperature, humidity, vibration, shock and other climatic and ambient conditions of the service application. Bulbs may be installed in thermowells or directly into the medium for temperature measurement. The filled system of the thermometer is a sealed unit and must remain sealed. The connecting tubing of remote units should be kept coiled to avoid sharp bends or kinks. Connecting tubing must not be cut. Thermometers can be rendered inaccurate during shipment despite care taken in packaging. To insure conformance to the accuracy to which the thermometer was manufactured, it should be checked before use.

Installation Procedure: The bulb should be located in the process at the point that will provide the temperature indication that is most representative of the process temperature. Circulation of the medium around the bulb is necessary for optimum response time and accuracy. For Direct Reading thermometers, use wrench flats when provided to install the thermometer. For Remote Reading thermometers – do not twist, kink, strain or cut the connecting tube. After the case has been mounted, uncoil and stretch out the connecting tubing, placing the bulb at its intended location. After installing the bulb, fasten the connecting tubing to a wall or other support to prevent damage. Position the connecting tubing to avoid extreme temperature. Since the connecting tubing length cannot be altered, any excess should be coiled on a 3" minimum radius and supported near the case.

Gas actuated thermometers have the following options and accessories:
 Flush Mounting Ring: Adapts the phenolic case for flush panel mounting.
 Windows: Optional acrylic or shatterproof glass available.

Gas Actuated Thermal Systems

The WIKA Gas Actuated dial thermometer systems are available in several bulb and material configurations. The application should be the determining factor in deciding both the type and material of the thermal system. For use in corrosive or otherwise more demanding installations, WIKA offers a 316 stainless steel bulb and capillary. The stainless steel system is protected with stainless steel spring armor or an optional stainless steel interlocking armor. **It should be noted that the unions on these systems DO NOT provide a pressure seal.** For pressure seals, always use in conjunction with a thermowell.

For installations requiring a pressure seal between the process and the atmosphere, a thermowell should be used. The bendable extension with a sliding union allows for variable insertion depths to place properly the active portion of the sensing bulb in the process for maximum accuracy. Aluminum duct flanges are available for threading union fitted bulbs into duct work to provide temperature indication of ducted air or gases.

Thermal Systems

Code No.	Bulb Type	Bulb Material	Capillary Material	Capillary Protection
0	Just-Rite®	316 stainless steel	N/A	N/A
1	Plain	316 stainless steel	316 stainless steel	Stainless steel spring armor**
8	½" NPSM Sliding Union	316 stainless steel	316 stainless steel	Stainless steel spring armor**

**Stainless steel interlocking Armor is available and must be used on systems longer than 40 feet.

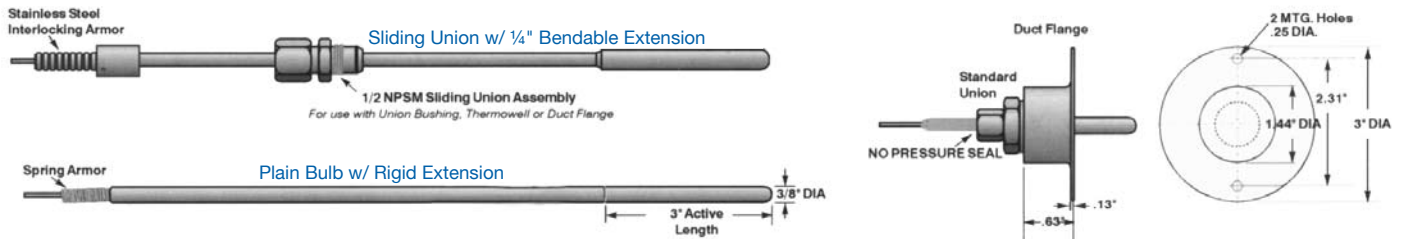

Bulbs available on WIKA gas actuated dial thermometers have 3/8" diameters to allow for installation in most existing piping and tanks. As the bulb is the temperature sensing element of the system, it must be placed where the most accurate temperature reading can be obtained. In piping, this is usually the center of the flow in an area of least turbulence. In tanks, this is an area that will represent a good average of the fluid temperature - usually close to the center of the tank. Available materials, lengths, and insertion depths for standard bulbs are listed in the accompanying chart.

Bulbs (All bulbs with threaded connections are ½" NPT)

Code No	Bulb Type	Bulb Material	Bulb Length	Extension Length	Insertion - "U" Thermowell Standard	Dimension Thermowell Lag Extension
1	Plain w/extension	316 SS	3"	12"	2½" - 10½"	-
4	Just-Rite	316 SS	4"	-	2½"	-
6	Just-Rite	316 SS	6"	-	4½"	2½"
9	Just-Rite	316 SS	9"	-	7½"	4½"
X	Just-Rite	316 SS	12"	-	10½"	6½"
7	Sliding Union	316 SS	3"	12"	2½" - 10½"	2½" - 7½"
8	Sliding Union	316 SS	3"	18"	2½" - 16½"	2½" - 13½"

*3" active length

Gas Actuated Thermometers

Type TI.R45, TI.R60



- Remote Reading
- Linear Scale
- High Temperature Capability

WIKA gas actuated remote reading dial thermometers are manufactured in three wall-mounted case styles: the cast aluminum back flange case with a 4½" dial size, the phenolic/GRP turret case (also with a 4½" dial size) and the stainless steel back flange case available in 4½" and 6" dial sizes. All may be specified with back or lower connected capillaries.

Standard Features

- **Accuracy:** ±1% of full range span
- **Over Range:** 50% of span above top of range or 1300°F, whichever is lower
- **Cases:** Drawn stainless steel, aluminum and Phenolic/GRP; for stem, surface or panel mount
- **Sizes:** 4½", 6"
- **Mounting Connections:** Lower or back on remote reading thermometers; adjustable angle on Just Rite
- **Bulb:** ¾" dia. x 3" active length standard in stainless steel; plain, sliding union
- **Capillary:** 316 stainless steel with stainless steel spring armor, or 316 stainless steel with stainless steel interlocking armor. 99' maximum
- **Dials:** White coated aluminum with black marking
- **Pointer:** Adjustable, balanced, aluminum with matte black finish
- **Ambient Error:** 0.25% at midscale of span per 25° F change in ambient temperature
- **Case Styles:** Wall mount-manufactured in 3 wall-mounted case styles: cast aluminum back flange case with 4½" dial size, the phenolic/GRP turret case with 4½" dial size, and stainless steel back flange case in 4½" and 6" dial sizes; may be specified with back or lower-connected capillaries.

Adjustable angle-flangeless, stainless steel case with bayonet bezel and 360° rotation. Stainless steel bulb can be rotated 180° to either side of the vertical axis of the stem to allow mounting from the top, bottom, or either side of an installation. Union fitted bulb can be threaded directly into a process connection or into a thermowell or duct flange.

Fahrenheit (outer scale)			Celsius (inner scale)		
Range:	Figure Interval	Subdivision	Range	Figure Interval	Subdivision
-320/100	50	5	-200/40	20	2
-120/120	20	2	-80/50	10	1
0/120	10	1	-20/50	5	1
0/160	20	2	-20/70	10	1
-40/180	20	2	-40/80	10	1
20/240	20	2	-10/115	10	1
0/300	25	5	-20/150	20	2
50/400	50	5	0/200	50	2
50/550	50	5	0/300	50	5
50/750	50	5	0/400	50	5
400/1200	100	10	200/650	50	5

(Case Styles cont.)

Just-Rite's standard bulb/stem thermal system is available in 4", 6" and 9" lengths; only 3" of the tip is active. Panel Mount WIKAI gas actuated remote reading dial thermometers accommodate most panel mounting requirements. Stainless steel "U" clamp cases are available in 4½" and 6". Aluminum front flange cases offer 4½" and 6" dial sizes. A stainless steel semi-flush front flange case is available in 4½" and 6" dial sizes. All panel mount thermometers are back connected. Turret phenolic case is available in 4½". Just-Rite is available in 4½" and 6".

Datasheets: TI.R45, TI.R60

Ordering Gas Actuated Thermometers

To order a WIKA Gas Actuated Thermometer, specify a complete part number from the following tables. Any special feature not shown must be specified in detail in addition to the model number.

Sample Part Number: R45 E L 3 8 7 05 006 00 WI

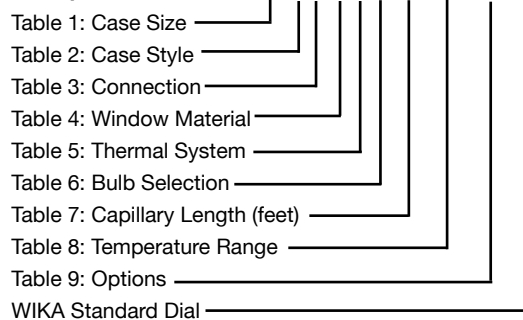

Table 1 - Case Size

Code	Description
R45	4½" Case
R60	6" Case

Table 2 - Case Type & Material

Code	Description	Material	Dial Size
K	Back Flange, bayonet ring	SS	4½", 6"
B	Back Flange, bayonet ring	Aluminum	4½", 6"
E	Turret, threaded ring	Phenolic	4½"
F	Front Flange, hinged ring	Aluminum	4½", 6"
S	Semi-flush Front Flange, bayonet ring	SS	4½", 6"
U	U-Clamp, bayonet ring	SS	4½", 6"
*V	Just-Rite, adjustable angle	SS	4½", 6"

*Capillary is not available. Fixed stem length only as specified in Table 6.

Table 3 - Connection

Code	Description	Case Size	Case Type
B	Back Connection	4½", 6"	ALL
L	Lower Connection	4½", 6"	4½" (K, B, E); 6" (K only)
*A	Adjustable Angle	4½", 6"	V only

*Capillary is not available. Fixed stem length only as specified in Table 6.

Table 4 - Window

Code	Description	Case Size	Case Type
3	Acrylic	4½"	ALL
4	Glass	4½", 6"	ALL
5	Shatterproof glass	4½"	E, K, S, U, V

Table 5 - Thermal System

Code	Bulb Type	Bulb Material	Capillary Material	Capillary Protection	w/5' Capillary
0	Adjustable angle 1/2" NPT	316SS	N/A	**N/A	
1	Plain	316SS	316SS	Spring armor*	
8	Sliding union 1/2" NPSM	316SS	316SS	Spring armor*	

* For systems up to 40 Ft.; Spiral Interlock required on all systems over 40 Ft. (see "SI" options, Table 9) **Capillary is not available; fixed stem length only as indicated in Table 6.

Table 6 - Bulb Selection

Code	Description	Union	Thermowell Immersion
ADJUSTABLE ANGLE OAL Thermowell Immersion			
4	3/8" Dia. x 3" Length (active), total 4"	4 1/4"	U = 2 1/2"
6	3/8" Dia. x 3" Length (active), total 6"	6 1/4"	U = 4 1/2"
9	3/8" Dia. x 3" Length (active), total 9"	9 1/4"	U = 7 1/2"
X	3/8" Dia. x 3" Length (active), total 12"	12 1/4"	U = 10 1/2"
PLAIN BULB - REMOTE			
1	3/8" Dia. x 3" Length (active) + 12" rigid extension		
SLIDING UNION (1/2" NPSM) BULB W/ BENDABLE EXTENSION (split fitting)			
7	3/8" Dia. x 3" Length (active) w/ 12" bendable extension	3 to 12"	U = 2 1/2" to 10 1/2"
8	3/8" Dia. x 3" Length (active) w/ 18" bendable extension	3 to 18"	U = 2 1/2" to 16 1/2"

Note: Thermowell Note: Gas actuated thermometers use standard process type 3/8" bore thermowells, if required. Order separately.

Special Table 5 & 6

Note:
The only possible thermal system/bulb combinations are as follows:
Plain Bulb: (11)
Adjustable Angle: (04), (06), (09), (0X)
Sliding Union: (87), (88)

Table 7 - Capillary Length

Code	Description
05	5 feet
10	10 feet
20	20 feet
30	30 feet
40	40 feet
*50	*50 feet
*80	*80 feet
XX	Adjustable angle case

* Requires "SI" option, see Table 9

Note:

Capillary can be configured to any whole foot, 99' and below; I.E., 08 = 8' capillary

Table 8 - Temperature Range

Code	Dual Scale F & C	
*001 ¹⁾	*-320/100°F	-200/40°C
002	-120/120°F	-80/50°C
003	0/120°F	-20/50°C
004	0/160°F	-20/70°C
005	-40/180°F	-40/80°C
006	20/240°F	-10/115°C
007	0/300°F	-20/150°C
008	50/550°F	0/300°C
009	50/750°F	0/400°C
**010 ¹⁾	**400/1200°F	200/650°C
011	50/400°F	0/200°C

* Requires "LT" option, See Table 9

** Requires "HT" option, See Table 9

¹⁾ Consult factory for NIST certification fees

Note:

Ranges marked with an asterisk in Table 8 reference same coding in Table 9 and require additional cost as indicated.

Table 9 - Options & Accessories

Code	Description	Case Size	Case Type
00	No Accessories	ALL	ALL
FR	Flush Mounting Ring	4 1/2"	E
*LT	Low Temperature (Cryogenic -320 F)	ALL	ALL
**HT	High Temperature (1200 F)	ALL	ALL
SI	316 SS Interlocking armor	ALL	ALL (Must be on systems over 40 Ft.)

* Requires "LT" option, See Table 9

** Requires "HT" option, See Table 9

Table 10 - Dial Logo

Code	Description
WI	WIKAI
BL	Blank

Gas Actuated Thermometers Temperature Switch Gauge Operating & Installation

Operation: WIKA's TI.TSG60 Temperature Switch Gauge is a patented technology that offers the best accuracy and least ambient error in remote temperature technology. Our direct drive edge-welded Bourdon tube offers a linear 180° dial arc while maintaining positive operation of micro switches with a 1½% accuracy full scale with better than ½% repeatability. Most important is the extremely low ambient error due to the NiSpan Bourdon tube and carbon-filled molecular sieve gas actuated patented technology. The cam adjustable switches offer little resistance to the powerful direct drive system offering consistent switch action with low repeatability error.

Our dual system SCADA version offers dual independent outputs with a failsafe redundant system. Total independence offers accuracy of remote electronics plus the reliability of the local mechanical dial readout all within one unit. The SCADA system comes fully calibrated and requires no field calibration.

Switching: Up to four filled adjustable switches are available with standard ratings of 10 AMP @ 125/250 VAC, non-inductive; 5 AMP @ 120 VAC, inductive; ½ AMP @ 125 VDC, non-inductive; ¼ AMP @ 250 VDC, non-inductive. The differential is 3% of the range. Switches are fully adjustable within the full range of the instrument. Switches can be set within 2° C of each other.

Mounting/Installation: The TI.TSG60 Temperature Switch Gauge is ideal for general industrial installations. Switches can be adjusted from the front of the unit without having to shut down or remove the instrument from the process.

Adjustment of the Set Points: The TI.TSG60 has up to four fully adjustable set points adjustable from the front of the unit. The set point indicators are easily adjusted and then locked in place with the following procedure:

1. Unscrew and remove the front bezel and lens counter-clockwise, as it is shipped from the factory hand tightened.
2. Using a small straight screwdriver, loosen the Set Point indicator and, using two fingers, position the indicator to the desired Set Point, and re-tighten the Set Point indicator.
3. Replace the bezel and lens and, using a strap wrench, rotate the bezel and lens clockwise ¾" beyond hand tight to fully engage the waterproof gasket. Do not over tighten.

Max. Hand Setting: The TI.TSG60 is available with a maximum registering hand that will indicate the highest temperature the unit records by staying at that point. To re-set the max, hand turn the knob counter-clockwise until it rests against the pointer.

Temperature Switch Gauge

Type TI.TSG60

- Temperature Switch Gauge
- Extremely Accurate
- Switch Rating up to 10 Amps



WIKAI's TI.TSG60 offers users an unprecedented combination of industrial strength performance with unmatched precision. This 6" gas actuated thermometer is accurate to within 1½% of scale and can tolerate up to 50% over range temperatures. Sealed inside the rugged stainless steel case are up to four single pole, double throw 10 amp switches for enabling a variety of switching actions. The thermal system is stainless steel, and filled with inert nitrogen making the TI.TSG60 ideal for steel and paper mills, refineries, petrochemical, and food and pharmaceutical plants.

Standard Features

- **Case and Bezel:** 304 Sstainless steel, 6.25" diameter
- **Case Style:** Bottom connected back flange
- **Process Connection:** ¾" x 3" 316 stainless steel bulb with 12" or 18" bendable extension, and ½" NPT one-time compression fitting
- **Window:** Lexan®
- **Range:** 11 standard ranges available. See "How to Order" on next page
- **Over Range:** 50% up to 500°F, except 10% on 0 -120°C and 0 - 250°F
- **Capillary:** Stainless steel with stainless steel interlocking armor; up to 99'
- **Switch Rating:** 10 amp @ 125/250 VAC, non-inductive; 5 amp @ 120 VAC, inductive; ½ amp @ 125 VDC, non-inductive; ¼ amp @ 250 VDC, non-inductive

Datasheet: TI.TSG60

Ordering Gas Temperature Switch Gauge

Sample Part Number: TSG60 08 3 A3 X7 25 SG WI

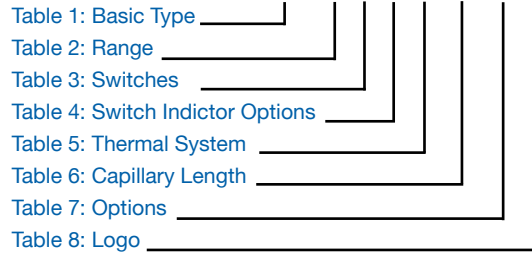

Table 1 - Type

Code	Description
TI.TSG60	6" back flange temperature switch gauge with Conxall Connector Harness 5" wire length

Table 2 - Range

Code	Description	Code	Description
01 ⁽¹⁾	-450/50°F	07	0/1000°F
02 ⁽¹⁾	-320/200°F	08	-20/120°
03	0/250°F	09	-20/160°C
04	-50/350°F	10	-20/180°C
05	50/550°F	11	-20/200°C
06	50/750°F		

⁽¹⁾ Setup charge per lot, refer to price list

Table 3 - Switches

Code	Description
1	One adjustable switch (amphenol connector)
2	Two adjustable switches (amphenol connector)
3	Three adjustable switches (amphenol connector)
4	Four adjustable switches (amphenol connector)

Table 4 - Standard Switch Indicator Options

Code	Description
A1	Center switch indicator (1 switch)
A2	Right & left switch indicators (2 switches)
A3 ⁽²⁾	Right, left & center switch indicators (3 switches)
A4 ⁽²⁾	Right, left, right, left switch indicator (4 switches)

⁽²⁾ For adjacent switches, right and left side indicators will allow for closest proximity of switch settings.

ABBREVIATIONS

N/C - there is no charge for this option

Table 5 - Thermal System

Code	Description
X7	3/8"x3" bulb w/12" bendable extension, 1/2" NPT one-time adjustable compression fitting
X8	3/8"x3" bulb w/18" bendable extension, 1/2" NPT one-time adjustable compression fitting

Table 6 - Capillary Length

Code	Description
XX	Capillary length in feet

Table 7 - Options

Code	Description
SG	Safety glass
EX	Explosion proof

Table 8 - Logo

Code	Description
EH WI	WIKA
EH BL	Blank

Vapor Actuated Thermometers

Vapor Actuated Thermometers

Type TI.V20/TI.V25, TI.V35/TI.V45

- Remote Reading
- Highly Accurate
- Refrigeration Applications



WIKAI's vapor actuated thermometers are highly accurate and provide remote reading. They are available in U-clamp, front flange or back flange case configurations. WIKAI's vapor actuated thermometers are well suited for refrigeration, solar heating, and water treatment applications.

Standard Features

- **Case:** Stainless steel
- **Accuracy:** ± 1 scale division
- **Movement:** Heavy duty brass, rotary type
- **Ring:** Snap-in O-ring
- **Window:** Glass or polycarbonate
- **Pointer:** Aluminum, adjustable, black finish
- **Dial:** Aluminum, white background, black graduations
- **Bourdon Tube:** Phosphor bronze, soldered to socket and tip
- **Process Connection:** Plain, union or thermowell
- **Bulb:** Copper or stainless steel
- **Capillary:** Copper- plain or with braid armor; stainless steel- plain; stainless steel or with stainless steel interlocking armor

Datasheets: [TI.V20, TI.V25](#)
[TI.V35, TI.V45](#)

Ordering Vapor Actuated Thermometers

Sample Model No: V25 UB3 1690 05 06 WI

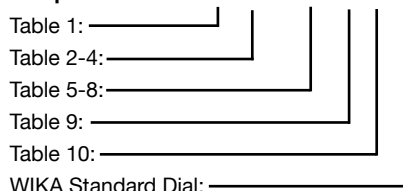

Table 1 - Case Size

Code	Description
V20	2"
V25	2½"
V35	3½"
V45	4½"

Table 2 - Case Style

Code	Case Type	Material	Case Size	Case Conn.
F	Front flange	SS	2", 2.5"	B
U	U-clamp	SS	2", 2.5"	B
Q	U-clamp	SS	3.5"	B
B	Back flange	SS	3.5", 4.5"	B, L
R	Front flange, semi flush	SS	3.5", 4.5"	B

Table 3 - Case Connection

Code	Description Case	Size	Case Type
B	Back connection	All	All
L	Lower connection	3.5", 4.5"	B

Table 4 - Case Front Window

Code	Description	Case Size	Case Type
3	Lexan snap-in lens	All	All
4	Glass lens w/ SS ring	2", 2½"	F, U
5	Glass lens w/ chrome plated brass ring	3½"	All
7	Glass lens w/ rubber ring	4½"	B, R
8	Glass lens w/ crimped SS ring, water proof	2", 2½"	U
9	Lexan threaded lens	2", 2½"	F, U, Q

ABBREVIATIONS

N/C - there is no charge for this option

Table 5 - Thermal Systems

Code	Bulb Type	Bulb Mat'l	Capillary Mat'l	Cap Protection
1	Plain	Copper	Copper	None
2	Plain	Copper	Copper	Cu. Braid
3	Plain	316 SS	316 SS	None
4	Union	Copper	Copper	None
5	Union	Copper	Copper	Cu. Braid
8	Union	316 SS	316 SS	Interlock Armor
9	Union	316 SS	316 SS	None

Table 6 - Bulb Selection (Use with codes 1, 2, & 3 Plain Bulb)

Table 6 - Bulb Selection

Thermal System			
No. 1 thru 3 above - Plain bulb for non-threaded process connection			
Code	Diameter	Length	Max. Sys. Length
2	3/8"	3.4"	25 Feet
3	3/8"	4.9"	50 Feet
4	3/8"	7.9"	99 Feet
5	3/8"	9.4"	99 Feet
6	3/8"	2.5"	5 Feet

Table 6 - Bulb Selection (Use with codes 4, 5, 8 & 9 Union Bulb)

Thermal System			
No. 4 through 9 above - Bulb with union for threaded process connection			
Code	Diameter	Length	Max. Sys. Length
1	7/16"	2.5"	10 Feet
2	7/16"	3.4"	25 Feet
3 ⁽¹⁾	7/16"	5.4"	50 Feet
4	7/16"	7.4"	99 Feet
5	7/16"	9.4"	99 Feet

⁽¹⁾ Required for lagging extension thermowell, see Table 7

Table 7 - Process Connection Fitting

Code	Description
1	Union 1/2" NPT
2	Union 3/4" NPT
3	Thermowell 1/2" NPT
4	Thermowell 3/4" NPT
5	Thermowell 1/2" NPT with 2" lag extension ⁽²⁾
6	Thermowell 3/4" NPT with 2" lag extension ⁽²⁾
7	Aluminum air duct flange (union only)
9	Plain bulb (always select with "plain bulb" - table 5; codes 1, 2, 3)

⁽²⁾ Can only be used with No. 3 bulb

Note: Available combinations for Thermal System (Table 5) and Bulb Selection (Table 6):

Plain: 12, 13, 14, 15, 16, 22, 23, 24, 25, 26, 32, 33, 34, 35, 36

Union: 41, 42, 43, 44, 45, 51, 52, 53, 54, 55, 81, 82, 83, 84, 85, 91, 92, 93, 94, 95

Also must consider Capillary Length (Table 9).

Table 8 - Process Connection Fitting

Code	Description
1	Brass
2	304 SS
3	316 SS
5	Aluminum (air duct flange only)
0	None (plain bulb only) (always select with "plain bulb" - table 5; codes 1, 2, 3)

Table 9 - Capillary Length

Code	Description
05	five feet
10	ten feet
15	fifteen feet
20	twenty feet
30	thirty feet
50	fifty feet
80	eighty feet

Note:

Capillary can be configured to any whole foot, 99' and below. I.E. - 08 = 8' capillary

Table 10 - Range

Code	Description
01	-40/60 F&C
02	-40/110 F&C
03	-20/100 F&C
04	0/150 F&C
05	0/180 F&C
06	20/220 F&C
07	40/240 F&C
08	30/300 F&C
09	100/350 F&C

Table 11 - Logo

Code	Description
WI	WIKA
BL	Blank

ABBREVIATIONS

N/C - there is no charge for this option

Reference for Table 5: Thermal Systems

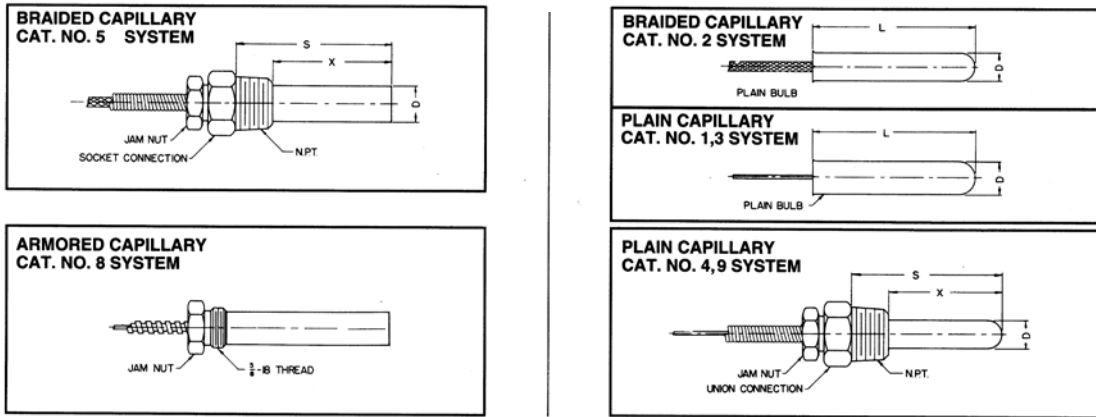

Reference for Table 7: Process Connection Fittings

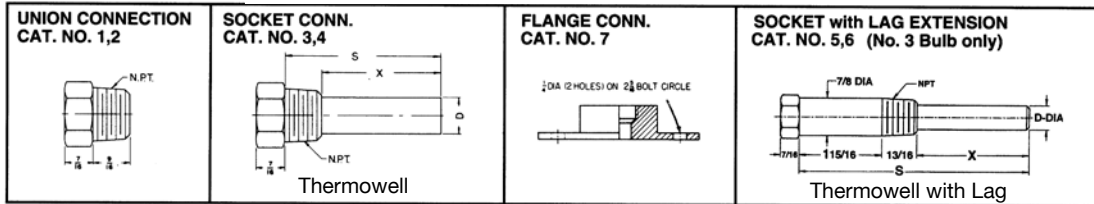

BULB DIMENSIONS

BULB NO. (CODE VI)	PLAIN CONNECTION		UNION CONNECTION			SOCKET CONNECTION			FLANGE CONNECTION	
	L	D	X	S	D	X	S	D	X	D
1	N/A	N/A	1 13/16	2 3/8	7/16	1 15/16	2 1/2	9/16	2 3/16	7/16
2	3 7/16	3/8	2 5/8	3 3/8	7/16	2 5/8	3 3/8	9/16	3	7/16
3	4 7/8	3/8	4 5/8	5 3/8	7/16	4 5/8	5 3/8	9/16	5	7/16
4	7 7/8	3/8	6 5/8	7 3/8	7/16	6 5/8	7 3/8	9/16	7	7/16
5	9 7/16	3/8	8 5/8	9 3/8	7/16	8 5/8	9 3/8	9/16	9	7/16
6	2 1/2	3/8	N/A	N/A	N/A	N/A	N/A	N/A	N/A	N/A

NOTE: "X" For Flange Connection is the Insertion Length from Tip of Bulb to Face of Flange. (Not Pictured)

Operation

WIKAL vapor actuated thermometers use an actuating liquid in the sensing bulb. When the bulb's temperature is increased, the liquid vaporizes, producing pressure which actuates the Bourdon tube and movement in the indicating gauge. The pointer indicates the temperature sensed at the bulb. The vapor pressure-to-temperature reading is non-linear. The scale graduations are further apart at the upper end of the gauge's range. Therefore, it is important to specify ranges in which the operating temperatures fall in the upper half of the scale. This provides a higher degree of accuracy and readability.

Non-Linear Dials

In the dials shown, note the scales are non-linear. In the dial in the upper left corner, the distance from -40°F to -20°F is less than from -20°F to 0°; this is critical in specifying WIKAL's vapor actuated thermometers. These thermometers have a limited range which offers easy-to-read, precise indication. Please note, these dials represent only a few of our standard temperature ranges.

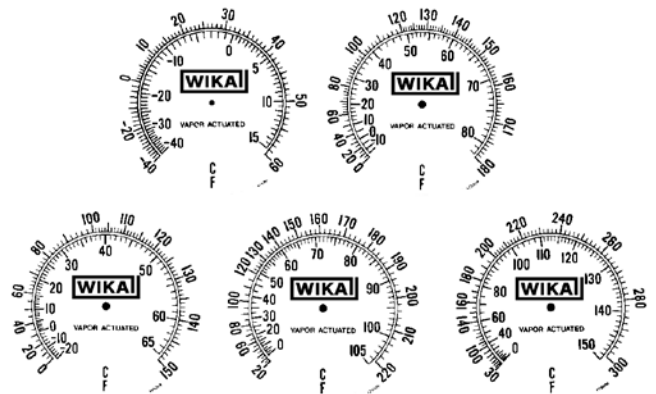

Industrial Glass Thermometers

Industrial Glass Thermometers

Type TI.61102/TI.61104
TI.62102/TI.62104

- Retro-Fits Existing Thread Sizes
- Small Compact Design
- Accuracy $\pm 1\%$ full scale



WIKA's 6" industrial glass thermometers are ideal for process piping, HVAC/R applications, diesel engines, compressors, and brine lines. This series of thermometers is manufactured in straight and back connected configurations, and come with a standard dual threaded brass socket with both $\frac{1}{2}$ " and $\frac{3}{4}$ " NPT connections.

Standard Features

- **Case:** V-shaped gray GE Valox® ; wide angle construction
- **Glass Front:** Protective glass cover retained within outer edges of case. Spring pressure created by V-scale secures glass against case and prevents rattling. Cover plate completes assembly.
- **Tube and Scale:** Blue liquid (non-mercury fill). V-shaped scale designed with extra large black numbers. Crosslocked scale holding device prevents loosening or shifting of scale and removes holes and screws that interfere with scale markings or numerals.
- **Stem and Socket Assembly:** Brass stem ensures fast response to temperature changes. The standard socket is made of brass and dual threaded for $\frac{1}{2}$ " and $\frac{3}{4}$ " NPT.
- **Accuracy:** $\pm 1\%$ of full scale range

Datasheets: [TI.61102](#), [TI.61104](#)
[TI.62102](#), [TI.62104](#)

Ordering Industrial Glass Thermometers

Type TI.61102, TI.61104
Type TI.62102, TI.62104

Sample Part No: **62102 06 213 P WI**



Table 1 - Thermometer & Stem Length

Code	Description	U
61102	Straight with 2" stem	1.31"
62102	Back with 2" stem	1.31"
61104	Straight with 4" stem	3.31"
62104	Back with 4" stem	3.31"

Table 2 - Connection

Code	Description
00	None - swivel nut connection
06	1/2" and 3/4" brass well

Table 3 - Range

°F ONLY			°C ONLY			COMBINATION °F & °C		
Code	°F	Scale Div.	Code	°C	Scale Div.	Code	°F & C	Scale Div.
201	-40/110	2	115	-40/45	1	001	-40/110 F (-45/45 C)	2/1
203	20/120	2	102	-5/50	1	003	20/120 (0/50 C)	2/1
213	20/180	2	118	0/110	2	013	20/180 (0/80 C)	2/2
207	30/240	2	108	0/150	2	007	30/240 (5/110 C)	2/2
208	30/300	5	106	10/200	5	008	30/300 (0/150 C)	5/2
209	50/400	5	n/a	n/a	n/a	009	50/400 (10/200 C)	5/5

Table 4 - Options

Code	Description
P	Plastic window

Table 5 - Logo

Code	Description
WI	WIKAL standard

Thermometer with 1/2" x 3/4" NPT Brass Thermowell

Model Number	Range Code	Description
6110206	*	Straight form with "U" dimension 1.31"
6210206	*	Back form with "U" dimension 1.31"
6110406	*	Straight form with "U" dimension 3.31"
6210406	*	Back form with "U" dimension 3.31"

Thermometer with Swivel Nut Connection

Model Number	Range Code	Description
6110200	*	Straight form with "U" dimension 1.31"
6210200	*	Back form with "U" dimension 1.31"
6110400	*	Straight form with "U" dimension 3.31"
6210400	*	Back form with "U" dimension 3.31"

*1/2" x 3/4" NPT dual threaded thermowell only #TA800-6206-BR- fits 2" stem length

Industrial Glass Thermometers

Type TI.701/TI.901

- **Retro-Fits Existing Thread Sizes**
- **Easy-to-Read Face**
- **HVAC/R Applications**



WIKA's TI.701 (7") and TI.901(9") industrial glass thermometers offer quick, easy-to-read temperature measurement for tough applications. Glass/mineral reinforced GE Valox® housings and spring mounted windows contribute to impact, shock and vibration resistance. WIKA industrial glass thermometers are the ideal choice for process piping, HVAC/R applications, diesel engines and compressors.

Standard Features

- **Case:** V-shaped case parts are molded of rugged GE Valox® 735 polyester, finished in textured black. Heavy glass window is spring-mounted to prevent rattles.
- **Stem:** To ensure sensitivity, bulb chambers are precision ground aluminum, tapered for a close-tolerance metal-to-metal contact with matching tapered socket. Graphite is used as a conductor between bulb chamber and glass tube.
- **Locking Device:** Independent adjustable case locknut and angle adjusting screw provide 360° positioning of case and stem.
- **Adjustable Joint:** Matching GE Valox® joint completely encloses capillary for thermal system protection.
- **Tube and Capillary:** Blue liquid (non-mercury fill) standard; magnifying lens tube is silicone shock-mounted to increase service life. Guaranteed accurate to within $\pm 1\%$ of scale range.
- **Scale:** Permanently baked-on, bold black graduations are printed on white-coated aluminum. No mounting screws obscure scale. Scale adjusts through locking device at top of instrument.
- **Accuracy:** $\pm 1\%$ of full scale range

Datasheets: [TI.901_TI.701](#)

Ordering Industrial Glass Thermometers

Type TI.701, TI.901

Sample Part No: **901 06 02 207 X WI**

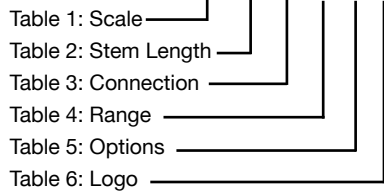

Range Code	°F	°F Scale Division	Range Code	°C	°C Scale Division
201	-40/110	2	101	-40/50	1
204	0/120	1	104	0/100	1
205	0/160	2	105	0/160	2
206	30/180	2			
207	30/240	2			
208	30/300	5			
*210	50/550	5			

*Requires aluminum case

Factory Stock

Part Number	Description
9010300004WI	9" scale, 3½" stem, 0/120°F & °C
9010300007WI	9" scale, 3½" stem, 30/240°F & °C
9010300204WI	9" scale, 3½" stem, 0/120°F
9010300205WI	9" scale, 3½" stem, 0/160°F
9010300206WI	9" scale, 3½" stem, 30/180°F
9010300207WI	9" scale, 3½" stem, 30/240°F
9010301204WI	9" scale, 3½" stem, with ¾" NPT brass thermowell 0/120°F
9010301207WI	9" scale, 3½" stem, with ¾" NPT brass thermowell 30/240°F
9010300005WI	9" scale, 3½" stem, 0/160°F & °C
9010600204WI	9" scale, 6" stem, 0/120°F
9010600208WI	9" scale, 6" stem, 30/300°F
9010601208WI	9" scale, 6" stem, with ¾" NPT brass thermowell 30/300°F

NOTE: Stock items shown in **bold, blue** print.

Table 1- Scale

Code	Description
701	7" scale, swivel nut connection
901	9" scale, swivel nut connection
702	7" scale, perforated stem for duct flange
902	9" scale, perforated stem for duct flange

Table 2- Stem Length

Code	Description
03	3½" stem
06	6" stem
09	9" stem
12	12" stem

Table 3- Connection

Code	Description
00	Swivel nut connection (no thermowell)
01	¾" NPT brass, thermowell
02	¾" NPT brass with lagging extension
03	¾" NPT brass union hub
04	Duct flange, reversible with or without lagging extension

Table 4- Ranges

Range Code	°F	°C	F Scale Division °	C Scale Division °
001	-40/110	-40/43	2	1
004	0/120	-17/49	1	1
005	0/160	-15/70	2	1
006	30/180	0/80	2	1
007	30/240	0/115	2	1
008	30/300	0/150	5	2
*010	50/550	10/290	5	5

*Requires aluminum case

Table 5- Options

Code	Description
P	7" plastic window
P	9" plastic window
A	7" or 9" aluminum case (required above 300°F or 160°C)

Note: "Blue" Liquid Fill is standard (550°F max. scale)

Table 6 - Logo

Code	Description
WI	WIKAL

Ordering Industrial Glass Thermometers (cont'd)

Type TI.701, TI.901

Custom (Non-Stock) Industrial Glass Thermometers

T-85 Thermowell Conversion Kit

Part Number

TA800-0T85

This conversion kit offers an easy, inexpensive way to install a WIKA bimetal thermometer in a glass industrial thermometer's thermowell. For more information, please consult factory.

7" & 9" Scale Industrial Thermometers with Swivel Nut Connection (no thermowell)

Model Number	Connection	Range	Logo	Description
70103	00	See chart	WI	7" scale, 3½" stem
70106	00	See chart	WI	7" scale, 6" stem
70109	00	See chart	WI	7" scale, 9" stem
70112	00	See chart	WI	7" scale, 12" stem
90103	00	See chart	WI	9" scale, 3½" stem
90106	00	See chart	WI	9" scale, 6" stem
90109	00	See chart	WI	9" scale, 9" stem
90112	00	See chart	WI	9" scale, 12" stem

7" & 9" Scale Industrial Thermometers Complete with ¼ NPT Brass Thermowell, with or without Lagging Extension

Model Number	Connection	Range	Logo	Description
70103	01	See chart	WI	7" scale, 3½" stem with thermowell
70106	01 or 02	See chart	WI	7" scale, 6" stem with thermowell (01) or well with lagging extension (02)
70109	01 or 02	See chart	WI	7" scale, 9" stem with thermowell (01) or well with lagging extension (02)
70112	01 or 02	See chart	WI	7" scale, 12" stem with thermowell (01) or well with lagging extension (02)
90103	01	See chart	WI	9" scale, 3½" stem with thermowell
90106	01 or 02	See chart	WI	9" scale, 6" stem with thermowell (01) or well with lagging extension (02)
90109	01 or 02	See chart	WI	9" scale, 9" stem with thermowell (01) or well with lagging extension (02)
90112	01 or 02	See chart	WI	9" scale, 12" stem with thermowell (01) or well with lagging extension (02)

7" & 9" Scale Industrial Thermometers Complete with Flange

Model Number	Connection	Range	Logo	Description
70203	04	See chart	WI	7" scale, 3½" stem with reversible duct flange (with or without lagging ext.)
70206	04	See chart	WI	7" scale, 6" stem with reversible duct flange (with or without lagging ext.)
70209	04	See chart	WI	7" scale, 9" stem with reversible duct flange (with or without lagging ext.)
70212	04	See chart	WI	7" scale, 12" stem with reversible duct flange (with or without lagging ext.)
90203	04	See chart	WI	9" scale, 3½" stem with reversible duct flange (with or without lagging ext.)
90206	04	See chart	WI	9" scale, 6" stem with reversible duct flange (with or without lagging ext.)
90209	04	See chart	WI	9" scale, 9" stem with reversible duct flange (with or without lagging ext.)
90212	04	See chart	WI	9" scale, 12" stem with reversible duct flange (with or without lagging ext.)

Single Scale Ranges

Range Code	°F	°F Scale Division	Range Code	°C	°C Scale Division
201	-40/110	2	101	-40/50	1
204	0/120	1	104	0/100	1
205	0/160	2	105	0/160	2
206	30/180	2			
207	30/240	2			
208	30/300	5			
*210	50/550	5			

*Requires aluminum case

Dual Scale Ranges

Range Code	°F	°C	°F Scale Division	°C Scale Division
001	-40/110	-40/43	2	1
004	0/120	-17/49	1	1
005	0/160	-15/70	2	1
006	30/180	0/80	2	1
007	30/240	0/115	2	1
008	30/300	0/150	5	2
*010	50/550	10/290	5	5

*Requires aluminum case

Solar Industrial Glass Thermometers

Type TI.D01



- **Solar Powered**
- **Easy-to-Read**
- **Adjustable Case**

WIKA's TI.D01 solar industrial thermometer offers fast, accurate, and easy-to-read temperature indications. This thermometer features a totally adjustable case to permit viewing at any angle, and its bulb and socket are completely interchangeable with standard industrial glass thermometers. The solar industrial thermometer is switchable between Fahrenheit and Celsius, and offers a sensing range of -50 to 300°F and -50 to 150°C, resolved in tenths of a degree, with accuracy to within $\pm 1\%$ of reading.

Standard Features

- **Range:** -50/300°F (-50/150°C)
- **Accuracy:** $\pm 1\%$ of reading or 1°, whichever is greater
- **Resolution:** 1/10° between -19.9/199.9°F (-28/93°C)
- **Lux Rating:** 10 lux (one foot candle)
- **Update:** 10 seconds
- **Ambient Operating Temperature:** -30/140°F (-35/60°C)
- **Humidity:** 100% maximum
- **Ambient Temperature Error:** None
- **Case:** High-impact ABS
- **Display:** $\frac{7}{16}$ " LCD Digits, wide ambient temperature range
- **Sensor:** Glass passivated thermistor

Available Options

Clear plastic protective cover: (part # TA600-0216)

Factory Stock

Part Number	Description
D010300WI	3½" stem, no thermowell
D010600WI	6" stem, no thermowell
D010301WI	3½" stem, with thermowell
D010601WI	6" stem, with thermowell

NOTE: Stock items shown in **bold, blue** print.

Non-Stock

Part Number	Description
D010304WI	3½" stem, with reversible flange air duct stem
D010604WI	6" stem, with reversible flange air duct stem
D010901WI	9" stem with thermowell

Accessories

Part Number	Description
TA600-0216	Clear plastic protective cover

Datasheet: TI.D01

Thermowells

Thermowells

Threaded, Flanged, Sanitary, Socket, Weld, Weld-in

- **Process Type Thermowells**
- **Used on Bimetal Thermometers**
- **Used on Gas Actuated Thermometers**



Thermowells for temperature instruments are recommended for all process systems where pressure, velocity or viscous, abrasive and corrosive materials are present individually or in combination. A properly selected thermowell protects the temperature instrument from possible damage resulting from these process variables. Furthermore, a thermowell permits removal of the temperature instrument for replacement, repair or testing without affecting the process media or the system.

Standard Features

- **Process Connections:** Threaded, flanged, sanitary, socket, weld, weld-in
- **Instrument Connection:** ½" NPSM standard (National Pipe Standard Mechanical); A straight pipe thread for mechanical joints)
- **Shank Configurations:** Reduced, straight, tapered
- **Bore Diameter:** .260", .385"
- **Materials:** Brass, AISI 304, AISI 316
- **Surface Finish:** Brass: 60-100 Ra; AISI 304 & AISI 316: 60-100 Ra sanitary (AISI 304 & AISI 316): 16-20 Ra

Datasheets: [TW.FL](#), [TW.SC](#), [TW.SW](#), [TW.TH](#), [TW.VS](#), [TW.WI](#)

Thermowell Terminology

Process Connection: External means to connect thermowell to process piping system. Wells can be threaded, bolted (to matching flange), clamped or welded in place.

Instrument Connection: Internal threads to connect temperature instrument to thermowell.

"U" Dimension: Length of well inserted into the piping system. Measured from the base of the process connection to the end tip of well.

"T" Dimension: Also called lagging extension. Extends length between the instrument and process connections to accommodate vessel or piping insulation. Standard length is 3" (2" for a well with a 2½" "U" dimension).

"S" Dimension: Instrument insertion length into well.

Bore Diameter: Dimension of internal bore to match the diameter of the instrument stem/bulb inserted into the well. The .260" and .385" bore sizes fit instrument stem/bulb diameters of ¼" and ⅜" respectively. Bore length equals "S" dimension.

Root Diameter: Diameter of well shank below process connection. This dimension varies with process connection and/or shank design.

Tip Diameter: Diameter of well shank at the end tip of well. This dimension may vary with process connection and/or shank design.

Reduced Shank: Also called reduced tip. The shank O.D. is reduced over the last 2½" of the "U" dimension from the standard root diameter to a ½" O.D. The stepped shank is available with a .260" bore size only.

Straight Shank: Shank O.D. is the same from the root diameter to the tip diameter. The straight shank is generally used with a .385" bore size but a .260" bore size is available.

Tapered Shank: Shank O.D. is gradually reduced from the root diameter to the tip diameter. Available with a .260" or .385" bore size. The tapered shank is recommended for heavy duty applications characterized by high vibration, pressure, temperature and/or velocity.

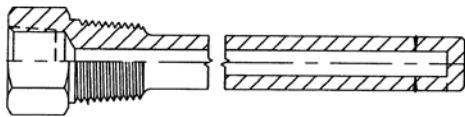

Threaded Straight Configuration

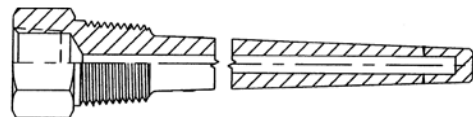

Threaded Tapered Configuration

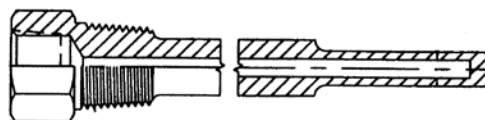

Threaded Reduced (Stepped) Configuration

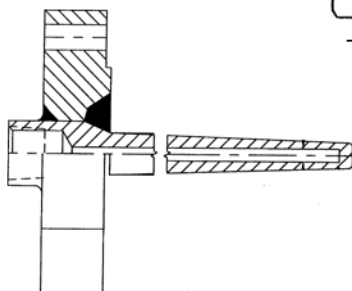

Flanged Tapered Configuration

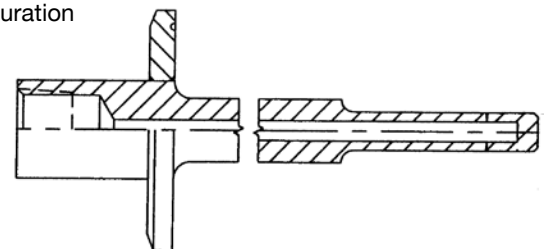

Sanitary Reduced Configuration

Thermowells

For Bimetal Thermometers & Gas Actuated Thermometers

CODING EXAMPLES

Type	Part Number	Process Connection	Bore/Type	Lag	Shank Design	"U" Dim.	Material	Rating	Facing
Threaded	75-TH2R-045-CC	¾" NPT	.260/threaded	None	Stepped	4½"	304SS		
Threaded	75-TH2LT-055-SS-T5	¾" NPT	.260/threaded	5" Lag	Tapered shank	5½"	316SS		
Flanged	15-FL2T-070-SS-150RF	1½" flanged	.260/flanged	None	Tapered shank	7"	316SS	150#	RF
Sanitary	10-SC2R-045-SS	1" sanitary	.260/sanitary	None	Stepped shank	4½"	316SS		
Socket weld	75-SW2R-045-CC	¾" NPT	.260/skt weld	None	Stepped	4½"	304SS		

WIKA THERMOWELL PRODUCT CODING EXPLANATION

Process Connection	Type / Bore Dia.	Lag	Shank Design	Standard "U" Dimensions (No Lag)		For Stem Length	Standard Material	Cap & Chain
				Type FL	All Other Types			
50 = ½"	TH2 = Threaded/.260	Blank=No lag	R = Reduced	N/A	*015 = 1 ⁵ / ₈ "	2½"	BR=Brass	2= ST.ST.
75 = ¾"	TH3 = Threaded/.385	L=Standard lag	S = Straight	020 = 2"	025 = 2½"	4"	CC=304ss	
10 = 1"	FL2 = Flanged/.260		T = Tapered	040 = 4"	045 = 4½"	6"	SS=316ss	
12 = 1¼"	FL3 = Flanged/.385			070 = 7"	075 = 7½"	9"	CS=Carbon steel	
15 = 1½"	SC2 = Sanitary/.260			100 = 10"	105 = 10½"	12"	MO=Monel	
20 = 2"	SC3 = Sanitary/.385			130 = 13"	135 = 13½"	15"	CP=Carp.20	
	SW2 = Socket weld/.260			160 = 16"	165 = 16½"	18"	IN=Inconel 600	
	SW3 = Socket weld/.385			220 = 22"	225 = 22½"	24"	NI=Nickel	
				Standard "U" with lag ("T")			HB=Hastelloy B	
				Type FL	All Other Types		HC=Hastelloy C	
				020 = 2" (T=2")	025 = 2½" (T=2")	6"	TA=Tantalum	
				040 = 4" (T=3")	045 = 4½" (T=3")	9"	TI=Titanium	
				070 = 7" (T=3")	075 = 7.½" (T=3")	12"	TC= Teflon coated	
				100 = 10" (T=3")	105 = 10½" (T=3")	15"	Other material, consult factory for pricing.	
				130 = 13" (T=3")	135 = 13½" (T=3")	18"		
				190 = 19" (T=3")	195 = 19½" (T=3")	24"		

For Flanged Well, Specify Rating & Facing

Rating	Facing
150#	
300#	FF=Flat Face flange
600#	RF=Raised Face flange
900#	RJ=Ring Joint flange
1500#	

*Note: For ½" NPT process connection the "U" dimension becomes 1" to accommodate ½" NPSM female thread. Order as "010", i.e. 50TH2R010CC.

Thermowells TH Threaded Configuration

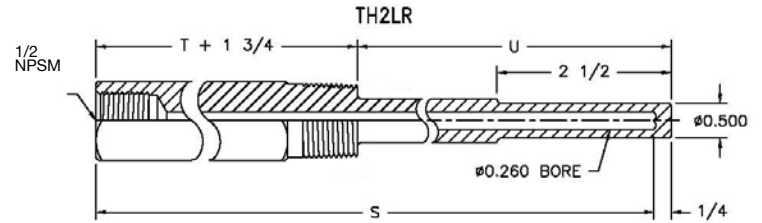
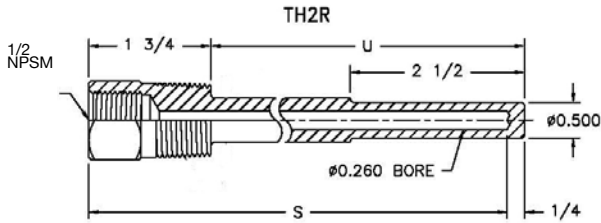

External Thread P	Stem Length S	Insertion Length U	Shank Diameter B
1/2"	4"	2 1/2"	-
	6"	4 1/2"	.625"
	9"	7 1/2"	.625"
	12"	10 1/2"	.625"
	15"	13 1/2"	.625"
	18"	16 1/2"	.625"
3/4"	2 1/2"	1 5/8"	.5"
	4"	2 1/2"	-
	6"	4 1/2"	.75"
	9"	7 1/2"	.75"
	12"	10 1/2"	.75"
	15"	13 1/2"	.75"
1"	18"	16 1/2"	.75"
	24"	22 1/2"	.75"
	2 1/2"	1 5/8"	.5"
	4"	2 1/2"	-
	6"	4 1/2"	.875"
	9"	7 1/2"	.875"

External Thread P	Stem Length S	Insertion Length U	Lag Extension T	Shank Dia. B
1/2"	6"	2 1/2"	2	-
	9"	4 1/2"	3	.625"
	12"	7 1/2"	3	.625"
	15"	10 1/2"	3	.625"
	18"	13 1/2"	3	.625"
	24"	19 1/2"	3	.625"
3/4"	6"	2 1/2"	2	-
	9"	4 1/2"	3	.75"
	12"	7 1/2"	3	.75"
	15"	10 1/2"	3	.75"
	18"	13 1/2"	3	.75"
	24"	19 1/2"	3	.75"
1"	6"	2 1/2"	2	-
	9"	4 1/2"	3	.875"
	12"	7 1/2"	3	.875"
	15"	10 1/2"	3	.875"
	18"	13 1/2"	3	.875"
	24"	19 1/2"	3	.875"

Material	Temperature - °F.					
	70°	200°	400°	600°	800°	1000° 1200°
Brass	5000	4200	1000	-----	-----	-----
Carbon Steel	5200	5000	4800	4600	3500	1500
A.I.S.I. - 304	7000	6200	5600	5400	5200	4500
A.I.S.I. - 316	7000	7000	6400	6200	6100	5100
Monel	6500	6000	5400	5300	5200	1500

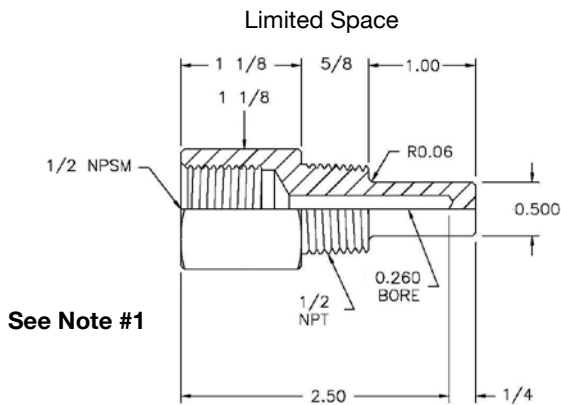

See Note #1

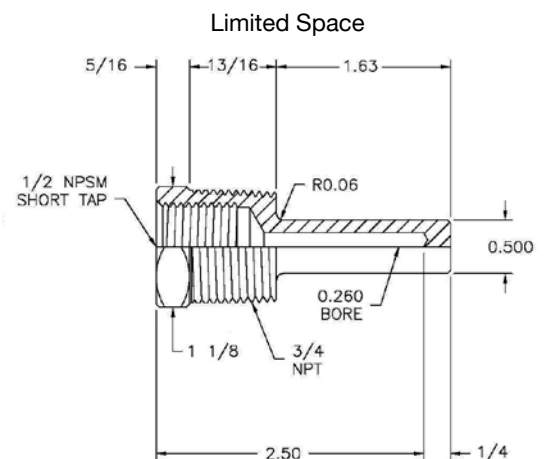

Notes:

- Normal "U" dimension on limited space well is 1 5/8" for 3/4" NPT and 1" NPT process connection. (For 1/2" NPT process connection, "U" dimension becomes 1" to accommodate 1/2" NPSM female thread. Order as "010", i.e. 50TH2R010CC.

Thermowells TH Threaded Configuration

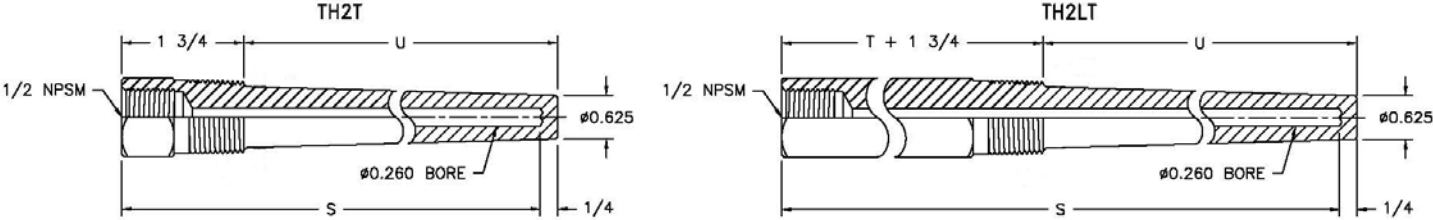

External Thread P	Stem Length S	Insertion Length U	Shank Diameter B
3/4"	4"	2 1/2"	.875"
	6"	4 1/2"	.875"
	9"	7 1/2"	.875"
	12"	10 1/2"	.875"
	15"	13 1/2"	.875"
	18"	16 1/2"	.875"
1"	24"	22 1/2"	.875"
	4"	2 1/2"	1.063"
	6"	4 1/2"	1.063"
	9"	7 1/2"	1.063"
	12"	10 1/2"	1.063"
	15"	13 1/2"	1.063"
18"	16 1/2"	1.063"	
24"	22 1/2"	1.063"	

External Thread P	Stem Length S	Insertion Length U	Lag Extension T	Shank Diameter B
3/4"	6"	2 1/2"	2	.875"
	9"	4 1/2"	3	.875"
	12"	7 1/2"	3	.875"
	15"	10 1/2"	3	.875"
	18"	13 1/2"	3	.875"
	24"	19 1/2"	3	.875"
1"	6"	2 1/2"	2	1.063"
	9"	4 1/2"	3	1.063"
	12"	7 1/2"	3	1.063"
	15"	10 1/2"	3	1.063"
	18"	13 1/2"	3	1.063"
	24"	16 1/2"	3	1.063"

PRESSURE - TEMPERATURE RATING							
Material	Material Temperature - °F.						
	70°	200°	400°	600°	800°	1000°	1200°
Brass	5300	4750	1100	-----	-----	-----	-----
Carbon steel	5950	5750	5450	5250	4000	1750	-----
A.I.S.I. - 304	7800	7050	6400	6150	6000	5190	1875
A.I.S.I. - 316	7800	7800	7250	7100	6950	5800	2720
Monel	7450	6850	6150	6100	5940	1750	-----

Thermowells TH Threaded Configuration

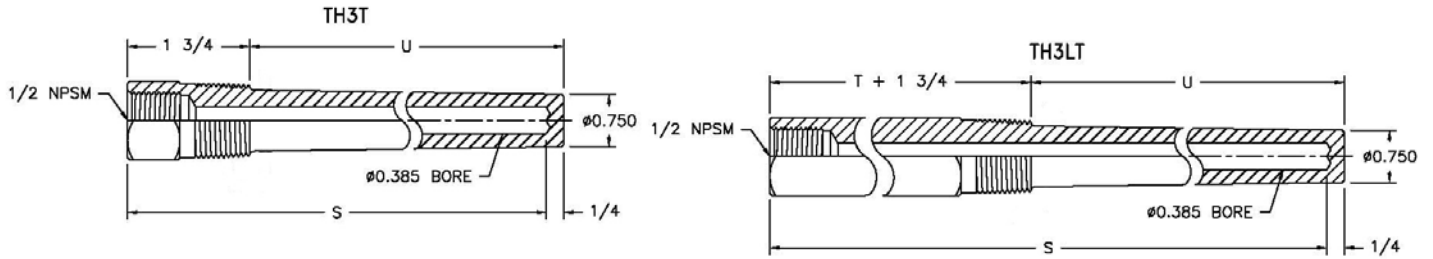

External Thread P	Stem Length S	Insertion Length U	Shank Diameter B
3/4"	4"	2 1/2"	.875"
	6"	4 1/2"	.875"
	9"	7 1/2"	.875"
	12"	10 1/2"	.875"
	15"	13 1/2"	.875"
	18"	16 1/2"	.875"
	24"	22 1/2"	.875"
1"	4"	2 1/2"	1.063"
	6"	4 1/2"	1.063"
	9"	7 1/2"	1.063"
	12"	10 1/2"	1.063"
	15"	13 1/2"	1.063"
	18"	16 1/2"	1.063"
	24"	22 1/2"	1.063"

External Thread P	Stem Length S	Insertion Length U	Lag Extension T	Shank Diameter B
3/4"	6"	2 1/2"	2	.875"
	9"	4 1/2"	3	.875"
	12"	7 1/2"	3	.875"
	15"	10 1/2"	3	.875"
	18"	13 1/2"	3	.875"
	24"	19 1/2"	3	.875"
	1"	6"	2 1/2"	2
9"		4 1/2"	3	1.063"
12"		7 1/2"	3	1.063"
15"		10 1/2"	3	1.063"
18"		13 1/2"	3	1.063"
24"		16 1/2"	3	1.063"

Material Temperature - °F.							
Material	70°	200°	400°	600°	800°	1000°	1200°
Brass	5000	4200	1000	-----	-----	-----	-----
Carbon Steel	5200	5000	4800	4600	3500	1500	-----
A.I.S.I. - 304	7000	6200	5600	5400	5200	4500	1650
A.I.S.I. - 316	7000	7000	6400	6200	6100	5100	2500
Monel	6500	6000	5400	5300	5200	1500	-----

Thermowells TH Threaded Configuration

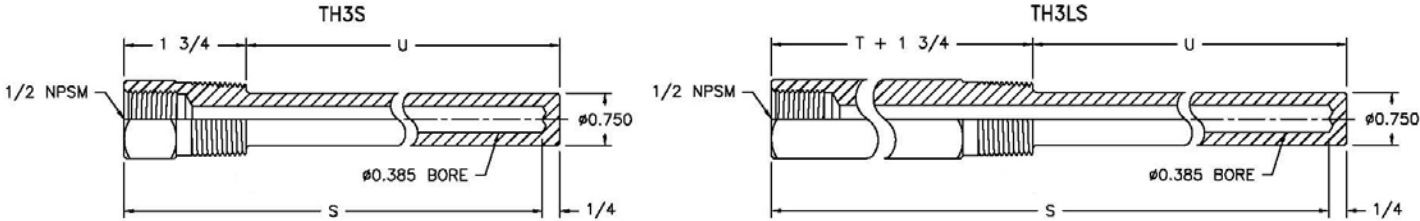

Extended Length P	Stem Length S	Insertion Length U
3/4"	4"	2½"
	6"	4½"
	9"	7½"
	12"	10½"
	15"	13½"
	18"	16½"
1"	24"	22½"
	4"	2½"
	6"	4½"
	9"	7½"
	12"	10½"
	15"	13½"
18"	16½"	
24"	22½"	

Extended Lag P	Stem Length S	Insertion Length U	Lag Extension T
3/4"	6"	2½"	2"
	9"	4½"	3"
	12"	7½"	3"
	15"	10½"	3"
	18"	13½"	3"
	24"	19½"	3"
1"	6"	2½"	2"
	9"	4½"	3"
	12"	7½"	3"
	15"	10½"	3"
	18"	13½"	3"
	24"	19½"	3"

Material	Temperature - °F.						
	70°	200°	400°	600°	800°	1000°	1200°
Brass	5000	4200	1000	-----	-----	-----	-----
Carbon Steel	5200	5000	4800	4600	3500	1500	-----
A.I.S.I. - 304	7000	6200	5600	5400	5200	4500	1650
A.I.S.I. - 316	7000	7000	6400	6200	6100	5100	2500
Monel	6500	6000	5400	5300	5200	1500	-----

Thermowells TH Threaded Configuration

Threaded Thermowells - General Use

Models TH2 (.260 bore) stepped (reduced) shank, without lag ONLY

Size	Model	No Lag U DIM	S DIM
1/2" NPT or 3/4" NPT	TH2R	1 5/8	2 1/2
		2 1/2	4
		4 1/2	6
		7 1/2	9
		10 1/2	12
		13 1/2	15
		16 1/2	18
		22 1/2	24

Size	Model	No Lag U DIM	S DIM
1" NPT	TH2R	1 5/8	2 1/2
		2 1/2	4
		4 1/2	6
		7 1/2	9
		10 1/2	12
		13 1/2	15
		16 1/2	18
		22 1/2	24

Threaded Thermowells - Special Configuration

Models TH2 (.260 bore) & TH3 (.385) bore, tapered, stepped (reduced) or straight shank, with or without lag

Size	Model	No Lag U DIM	With Lag		S DIM	
			U DIM	T DIM		
1/2" NPT or 3/4" NPT	TH2R	1 5/8	--	--	2 1/2	
	TH2S	2 1/2	--	--	4	
	TH2LR	4 1/2	2 1/2	2	6	
	TH3S	7 1/2	4 1/2	3	9	
	TH3LS	10 1/2	7 1/2	3	12	
	TH2T	13 1/2	10 1/2	3	15	
	TH2LT	16 1/2	13 1/2	3	18	
	TH3T	22 1/2	19 1/2	3	24	
	TH3LT					
1" NPT	TH2R	1 5/8	--	--	2 1/2	
	TH2S	2 1/2	--	--	4	
	TH2LR	4 1/2	2 1/2	2	6	
	TH3S	7 1/2	4 1/2	3	9	
	TH3LS	10 1/2	7 1/2	3	12	
	TH2T	13 1/2	10 1/2	3	15	
	TH2LT	16 1/2	13 1/2	3	18	
	TH3T	22 1/2	19 1/2	3	24	
	TH3LT					

Threaded Thermowell Factory Stock

Part Number

75TH2R015BR
75TH2R015CC
75TH2R015SS
75TH2R025BR
75TH2R025CC
75TH2R025SS
75TH2LR025SS
75TH2R045BR
75TH2R045CC
75TH2R045SS
75TH2T045CC
75TH2T045SS
75TH2LR045SS
75TH2R075CC
75TH2R075SS
50TH2R010BR
50TH2R010CC
50TH2R010SS
50TH2R025BR
50TH2R025CC
50TH2R025SS

Accessories

Description	Part #	Code
Brass cap & chain	N/A	Code 1
SS cap & chain	N/A	Code 2
SS tag wired on	N/A	-
Stamping on well	N/A	-
5.3 oz. tube heat transfer compound	2256045	-
Paper tag	N/A	-

NOTE: Stock items shown in **bold, blue** print.

Thermowells SW Socket/Weld Configuration

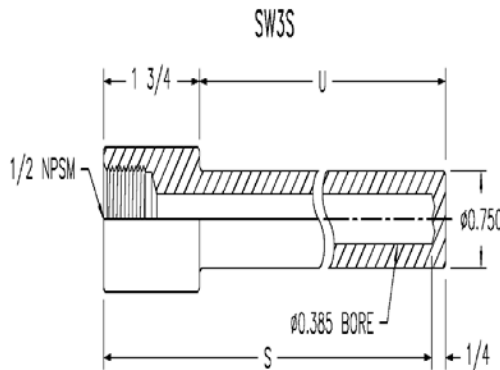
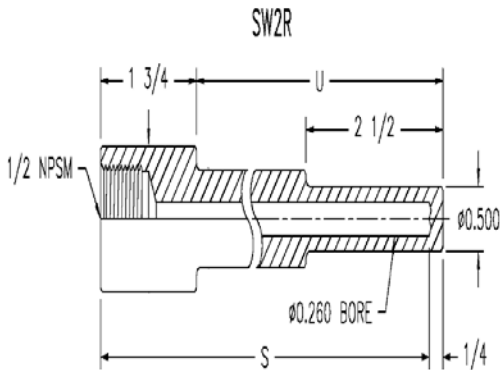

Pipe Size P	Stem Length S	Insertion Length U
3/4" 1.050 DIA.	4"	2 1/2"
	6"	4 1/2"
	9"	7 1/2"
	12"	10 1/2"
	15"	13 1/2"
	18"	16 1/2"
1" 1.315 DIA.	24"	22 1/2"
	4"	2 1/2"
	6"	4 1/2"
	9"	7 1/2"
	12"	10 1/2"
	15"	13 1/2"
18"	16 1/2"	
24"	22 1/2"	

Pipe Size P	Stem Length S	Insertion Length U
3/4" 1.050 DIA.	4"	2 1/2"
	6"	4 1/2"
	9"	7 1/2"
	12"	10 1/2"
	15"	13 1/2"
	18"	16 1/2"
1" 1.315 DIA.	24"	22 1/2"
	4"	2 1/2"
	6"	4 1/2"
	9"	7 1/2"
	12"	10 1/2"
	15"	13 1/2"
18"	16 1/2"	
24"	22 1/2"	

Material Temperature - °F.							
Material	70°	200°	400°	600°	800°	1000°	1200°
Brass	5000	4200	1000	-----	-----	-----	-----
Carbon steel	5200	5000	4800	4600	3500	1500	-----
A.I.S.I. - 304	7000	6200	5600	5400	5200	4500	1650
A.I.S.I. - 316	7000	7000	6400	6200	6100	5100	2500
Monel	6500	6000	5400	5300	5200	1500	-----

Thermowells SW Socket/Weld Configuration

Socket Weld

Models SW2 (.260 bore) & SW3 (.385 bore), stepped & straight shank, with or without lag

Size	Model	No Lag	With Lag		S	
		U DIM	U DIM	T DIM	DIM	
3/4"		2½	--	--	4	
	SW2R	4½	2½	2	6	
	SW2LR	7½	4½	3	9	
	SW3S	10½	7½	3	12	
	SWLS	13½	10½	3	15	
			16½	13½	3	18
			22½	19½	3	24

Size	Model	No Lag	With Lag		S	
		U DIM	U DIM	T DIM	DIM	
1"		2½	--	--	4	
	SW2R	4½	2½	2	6	
	SW2LR	7½	4½	3	9	
	SW3S	10½	7½	3	12	
	SWLS	13½	10½	3	15	
			16½	13½	3	18
			22½	19½	3	24

Accessories

Description	Part #	Code
SS cap & chain	N/A	Code 2
SS tag wired on	N/A	-
Stamping on well	N/A	-
5.3 oz. tube heat transfer compound	2256045	-
Paper tag	N/A	-

NOTE: These accessories also apply to Type TW.WI.

Thermowells FL Flanged Configuration

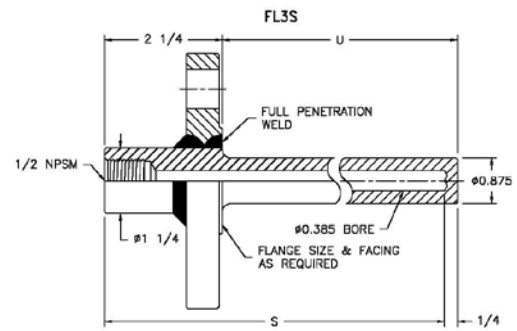
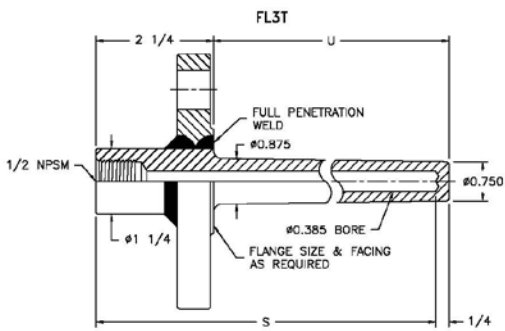
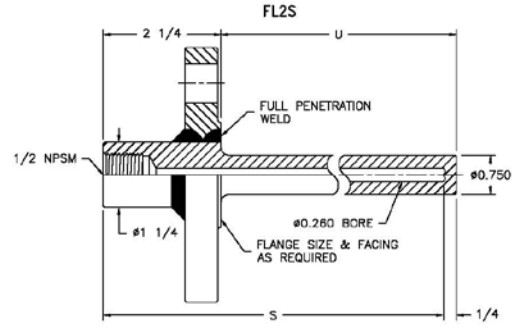
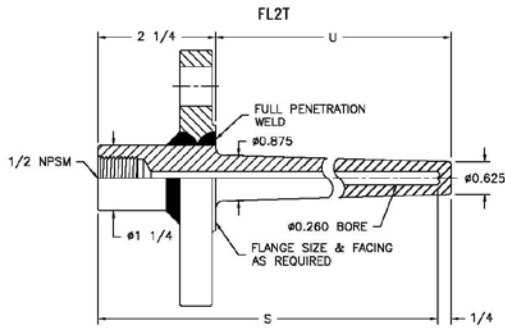

Stem Length	Insertion Length
S	U
4"	2"
6"	4"
9"	7"
12"	10"
15"	13"
18"	16"
24"	22"

Material	MAXIMUM FLANGE PRESSURE - TEMPERATURE RATING LBS. PER SQ. INCH						
	Temperature - °F. (FL2T/FL3T)						
	0°	200°	400°	600°	800°	1000°	1125°
Carbon Ssteel	----	UP ----	TO	-----	2500#		
A.I.S.I. - 304	----	UP ----	TO	-----		2500#	
A.I.S.I. - 316	----	UP ----	TO	-----			2500#
Monel	----	UP ----	TO	-----		2500#	

Thermowells SC Sanitary Configuration

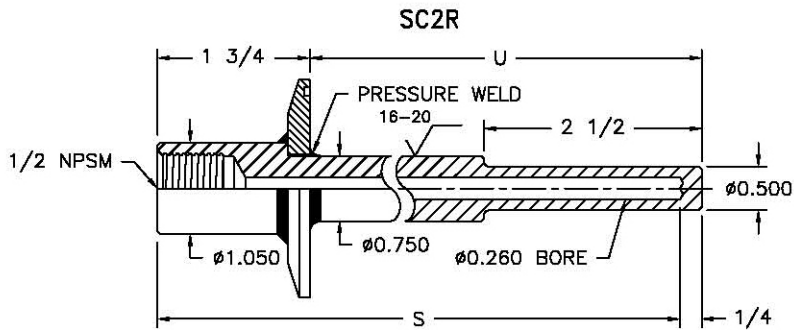

- Meets USDA and 3A Sanitary Standard 74-03.
- Available with 1", 1 1/2", 2", and 3" solid end caps. Special designs available upon request.
- Standard finish AISI 304 and AISI 316, 16-20 Ra.

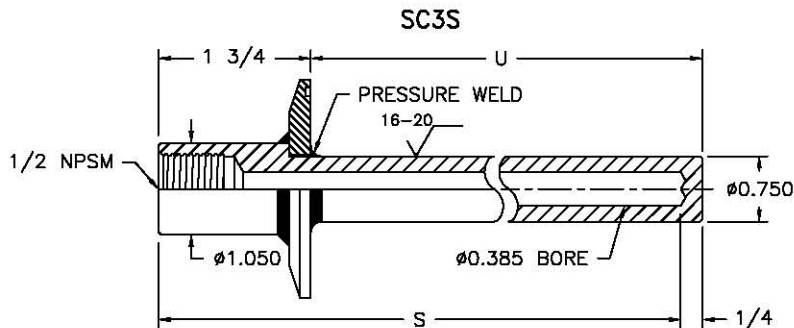

Note: Minimum stem length is 4"

Thermowells SC Sanitary Configuration

Sanitary

Type SC2 (.260 bore) & SC3 (.385 bore), stepped or straight shank, with or without lag

Size	Model	No Lag	With Lag		S DIM
		U DIM	U DIM	T DIM	
1"	SC2R	--	--	--	--
	SC2LR	2½	--	--	4
1½"	SC3S	4½	2½	2	6
	SC3LS	7½	4½	3	9

Size	Model	No Lag	With Lag		S DIM
		U DIM	U DIM	T DIM	
2"	SC2R	--	--	--	--
	SC2LR	2½	--	--	4
	SC3S	4½	2½	2	6
	SC3LS	7½	4½	3	9

Type SC2 (.260 bore) & SC3 (.385 bore), tapered shank, with or without lag

Size	Model	No Lag	With Lag		S DIM
		U DIM	U DIM	T DIM	
1"	SC2T	--	--	--	--
	SC2LT	2½	--	--	4
1½"	SC3T	4½	2½	2	6
	SC3LT	7½	4½	3	9

Size	Model	No Lag	With Lag		S DIM
		U DIM	U DIM	T DIM	
2"	SC2T	--	--	--	--
	SC2LT	2½	--	--	4
	SC3T	4½	2½	2	6
	SC3LT	7½	4½	3	9

Note: Sanitary thermowells are polished 16-20 RA per 3A Sanitary Standards

Accessories

Description	Part #	Code
Brass cap & chain	N/A	Code 1
SS cap & chain	N/A	Code 2
SS tag wired on	N/A	-
stamping on well	N/A	-
5.3 oz. tube heat transfer compound	2256045	-
Paper tag	N/A	-

Thermowells For Industrial Glass Thermometers

THERMOWELL PRODUCT CODING EXPLANATION

Process Connection	Type / Bore Dia.	Lag	Shank Design	Nominal Bulb Length Type TH5	For Stem Length	Standard Material	Cap & Chain
75 = 3/4" 10 = 1"	TH5 = Threaded .625 min. dia.	Blank=No lag L=Standard lag	R = Stepped	035 = 3 1/2" 060 = 6" 090 = 9"	3 1/2" 6" 9"	BR=Brass CC=304 ss SS=316 ss	1=Brass 2=ST.ST.

WIKA INDUSTRIAL THERMOWELL CODING EXPLANATION

Model TH5 (.625 bore) stepped shank, with or without lag

Size	Model	Lag			"S" DIM	Brass	304 SS	316 SS
		No lag "U" DIM	With lag "U" DIM	"T" DIM				
3/4" or 1"	TH5R	2 9/16"	-----	-----	3 1/2"			
		5 1/16"	2 9/16"	2 1/2"	6"			
	TH5LR	8 1/16"	5 1/16"	3"	9"			
		11 1/16"	8 1/16"	3"	12"			

Threaded Thermowells for Industrial Glass Thermometers- Factory Stock

Part Number
75TH5R035BR
75TH5R060BR
75TH5LR035BR

X denotes product availability

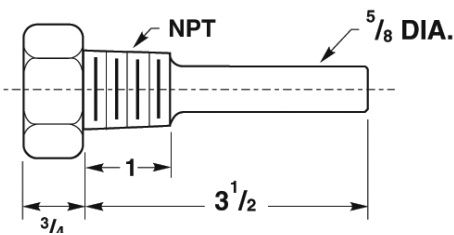

Standard Form

Part Number	NPT
75TH5R035BR	3/4"

Note: 1" NPT also available

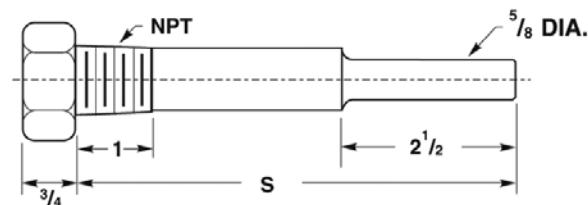

Standard Form

Part Number	S	NPT
75TH5R060BR	6	3/4"
75TH5R090BR	9	3/4"
75TH5R120BR	12	3/4"

Note: 1" NPT also available

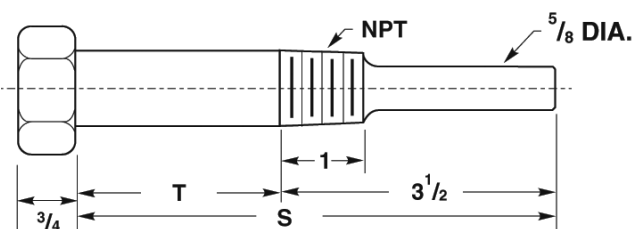

Lagging Extension

Part Number	S	T	NPT
75TH5LR060BR	6	2 1/2"	3/4"

Note: 1" NPT also available

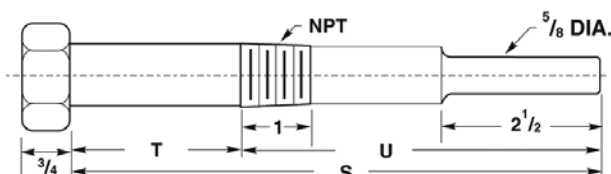

Lagging Extension

Part Number	S	T	U	NPT
75TH5LR090BR	9	3"	8 1/16"	3/4"
75TH5LR120BR	12	3"	5 1/16"	3/4"

Note: 1" NPT also available